

**Features**

- 2 channels of DC motor BTL driver
- 2 channels of BTL driver for coils with current feedback
- 1 channels forward/reverse control DC motor driver
- Built-in suspension function.
- Built-in thermal shutdown circuit.
- Operating voltage: 4.5V~13.2V

**Description**

The AT5665 is a 5-channel BTL driver IC. Two of them can drive DC motors and two can drive coils, such as the focus and tracking actuators of a CD-ROM/DVD-ROM/DVD-Player system, with current feedback. It also built-in one channel bi-direction DC motor driver for Tray.

**Applications**

CD-ROM/DVD-ROM/CD-RW drives  
DVD player.

**Block Diagram**

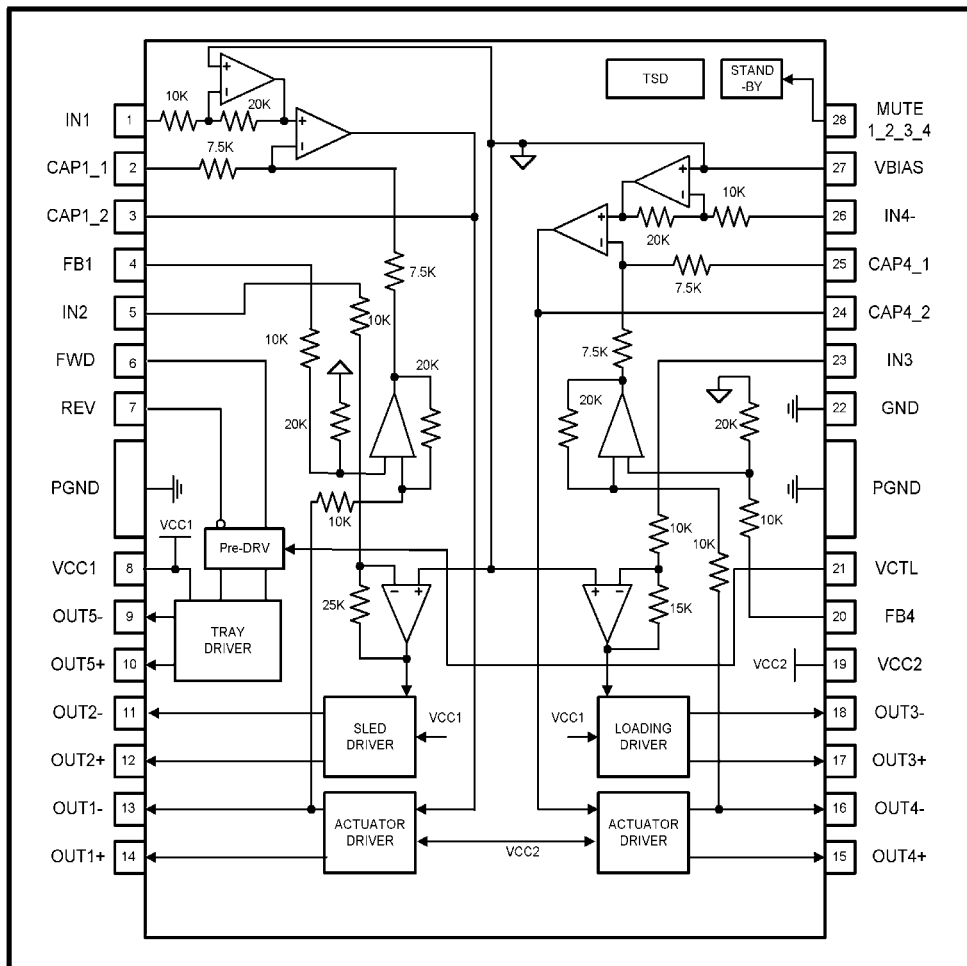

**Aimtron reserves the right without notice to change this circuitry and specifications.**

**Pin Descriptions**

Pin No.	Pin name	Function
1	IN1	CH1(Focus coil) input
2	CAP1_1	CH1 error amplifier filter capacitor connection 1
3	CAP1_2	CH1 error amplifier filter capacitor connection 2
4	FB1	CH1(Focus coil) feedback pin
5	IN2	CH2(Sled driver) input
6	FWD	CH5 forward input
7	REV	CH5 reverse input
8	VCC1	Power Supply 1
9	OUT5-	CH5(Tray driver) output(-)
10	OUT5+	CH5(Tray driver) output(+)
11	OUT2-	CH2(Sled driver) output (-)
12	OUT2+	CH2(Sled driver) output (+)
13	OUT1-	CH1(Focus coil) output (-)
14	OUT1+	CH1(Focus coil) output (+)
15	OUT4+	CH4(Tracking coil) output (+)
16	OUT4-	CH4(Tracking coil) output (-)
17	OUT3+	CH3(Loader) output (+)
18	OUT3-	CH3(Loader) output (-)
19	VCC2	Power Supply 2
20	FB4	CH4(Tracking coil) feedback pin
21	VCTL	CH5 Speed control input
22	GND	Ground
23	IN3	CH3(Loader) input
24	CAP4_2	CH4 error amplifier filter capacitor connection 2
25	CAP4_1	CH4 error amplifier filter capacitor connection 1
26	IN4-	CH4 (Tracking driver) input
27	VBIAS	VREF input pin
28	MUTE 1 2 3 4	Mute control for CH1,Ch2,CH3,CH4

**Notes:** The indicated polarities for the output pins are under the condition that all inputs are (+).  
The power supplies for the driver output are PVcc1 for the loader, PVcc2 for focus and tracking drivers, and Vcc for pre-block and sled driver. Therefore, make sure  $V_{cc} \geq PV_{cc1,2}$ .

**Pin Out**

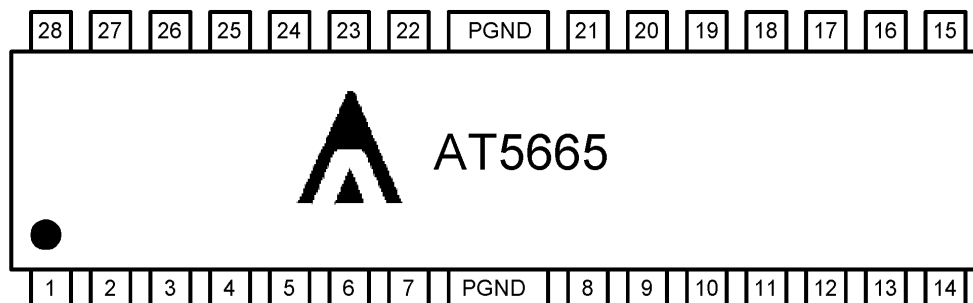

**Ordering Information**

Part number	Package	Marking
AT5665H	28-pin HSOP	AT5665H

**Power Dissipation (Ta = 25°C)**

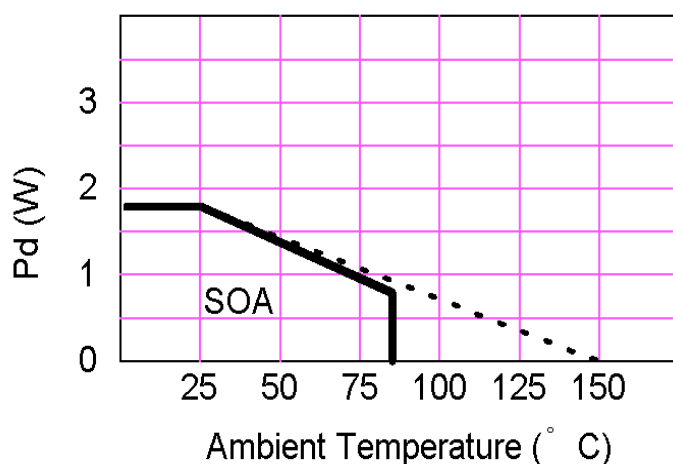

Condition: mount on 50x50 mm<sup>2</sup> t=1.0mm paper phenol PCB

**Absolute maximum ratings (Ta = 25°C)**

Parameter	Symbol	Limits	unit
Power supply voltage	VCC1,2	13.5	V
Power dissipation	P <sub>d</sub>	1.7	W
Operating temperature	T <sub>opr</sub>	-30~+80	°C
Storage temperature	T <sub>stg</sub>	-55~+150	°C

NOTE:\*

1. Power dissipation reduces 13.6mW / °C for using above Ta=25°C
2. Do not exceed Pd and SOA.

**Recommended operating conditions (Ta = 25°C)**

Parameter	Symbol	Limits	unit
Power supply voltage	VCC1	4.0~13.2	V
	VCC2	4.0~Vcc1	V

**Electrical characteristics**

(unless otherwise noted, Ta = 25°C, VCC1 = 12V, VCC2 = 5V, VBIAS = 2.5V, R<sub>L1</sub> = R<sub>L2</sub> = 8Ω, R<sub>L3</sub> = R<sub>L4</sub> = 12Ω)

Parameter	Symbol	Min.	Typ.	Max.	Unit	Conditions
Quiescent current	I <sub>OC</sub>	-	18	27	mA	No Load
Mute quiescent current	I <sub>QSB</sub>	-	-	5	mA	CH5 active
Mute ON voltage	V <sub>SBON</sub>	0	-	0.5	V	
Mute OFF voltage	V <sub>SBOFF</sub>	2.0	-	-	V	
<b>&lt;Actuator driver&gt;</b>						
Output current offset	I <sub>O1,2</sub>	-6	-	6	mA	
Maximum output voltage	V <sub>O1,2</sub>	3.6	4.0	-	V	V <sub>IN</sub> = V <sub>BIAS</sub> ±1.5V
Gain	G <sub>m</sub>	1.3	1.5	1.7	A/V	V <sub>IN</sub> = V <sub>BIAS</sub> ±0.2V
<b>&lt;Sled motor driver&gt;</b>						
Output voltage offset	V <sub>OFFSL</sub>	-100	0	100	mV	
Maximum output voltage	V <sub>O3MAX</sub>	7.5	9.0	-	V	V <sub>IN</sub> = V <sub>BIAS</sub> ±1.5V
Closed loop gain	G <sub>VSL</sub>	18.0	20.0	22.0	dB	V <sub>IN</sub> = V <sub>BIAS</sub> ±0.2V
<b>&lt;Loader motor driver&gt;</b>						
Output voltage offset	V <sub>OFFLD</sub>	-50	0	50	mV	
Maximum output voltage	V <sub>O4max1</sub>	7.5	9.0	-	V	V <sub>IN</sub> = V <sub>BIAS</sub> ±2.0V
Maximum output voltage	V <sub>O4max2</sub>	3.6	4.0	-	V	V <sub>IN</sub> = V <sub>BIAS</sub> ±1.5V VCC1 = 5V
Closed loop gain	G <sub>VLD</sub>	13.5	15.5	17.5	dB	V <sub>IN</sub> = V <sub>BIAS</sub> ±0.2V
Gain error	ΔG <sub>VLD</sub>	0	1	2	dB	V <sub>IN</sub> = V <sub>BIAS</sub> ±0.2V
<b>&lt;Tray motor driver&gt;</b>						
Maximum output voltage	V <sub>O5max1</sub>	-	6.0	-	V	R <sub>L5</sub> = 45Ω, R <sub>VCTL</sub> = 400Ω,
		3.8	-	4.2	V	R <sub>L5</sub> = 45Ω, R <sub>VCTL</sub> = 0Ω, VCC1 = VCC2 = 5V
Output voltage offset	V <sub>OFFTR</sub>	-50	0	50	mV	
Input high level voltage	V <sub>IH</sub>	2.0	-	-	V	
Input low level voltage	V <sub>IL</sub>	-	-	0.8	V	

**Tray Motor Driver**

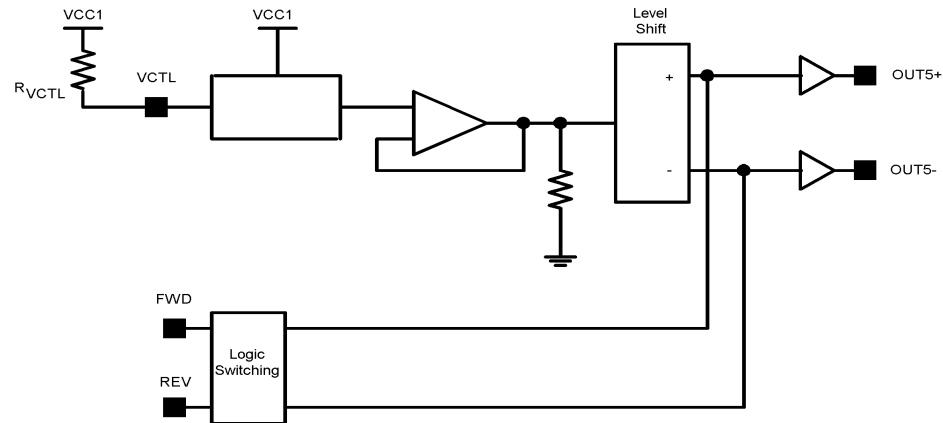

**Fig1.**

Input		Output		
FWD	REV	OUT5+	OUT5-	Status
High	High	Low	Low	Break
High	Low	High	Low	Forward
Low	High	Low	High	Reverse
Low	Low	Open	Open	Standby

**Tray Motor Speed Control**

The amplitude of the output voltage is controlled by VCTL(pin21). If you want to control differential output voltage of the tray, insert external resistor  $R_{VCTL}$  as shown in figure 1.

**Test Circuit**

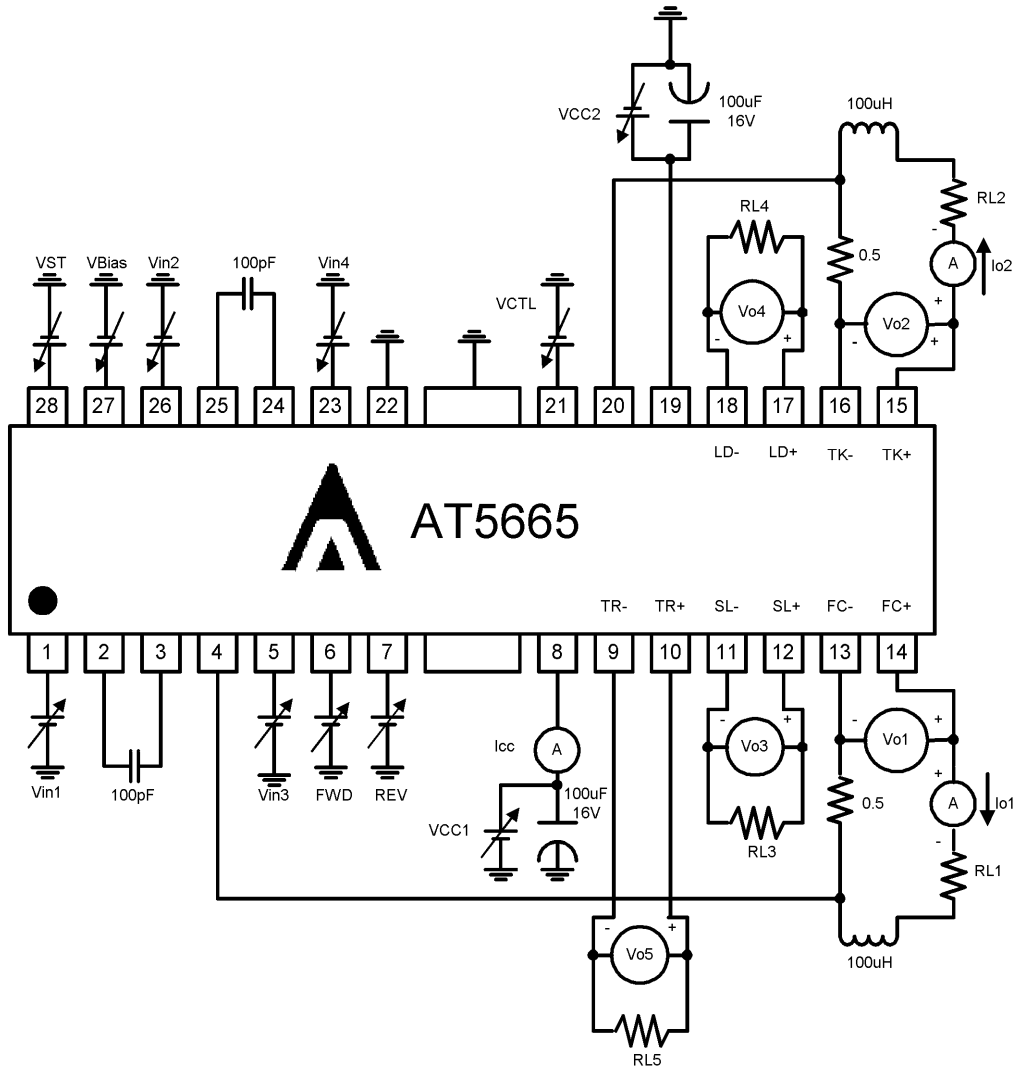

**Typical Curve**

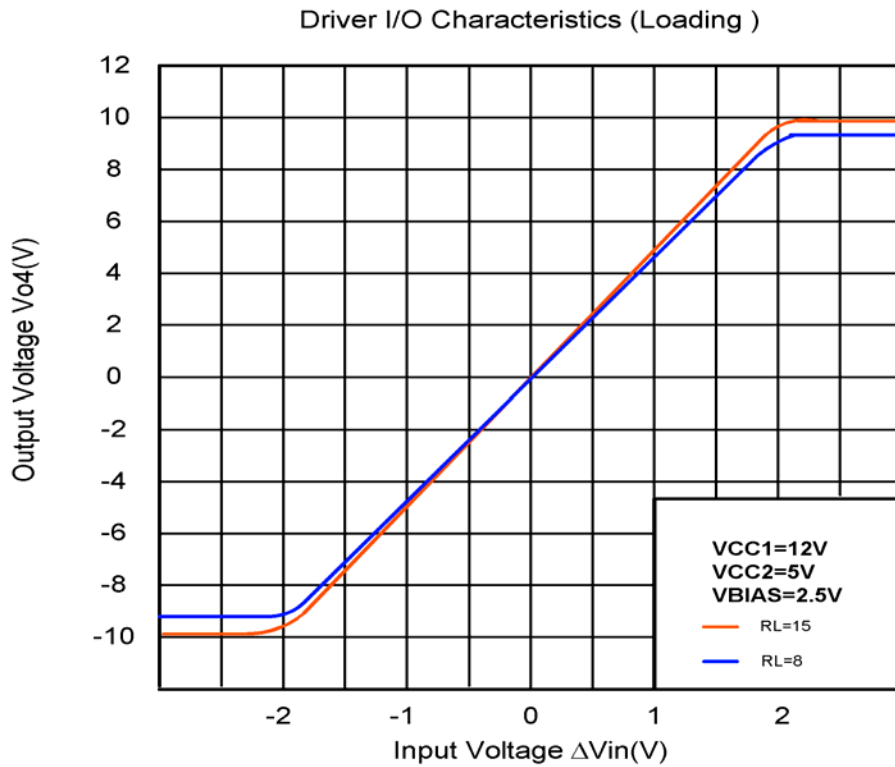
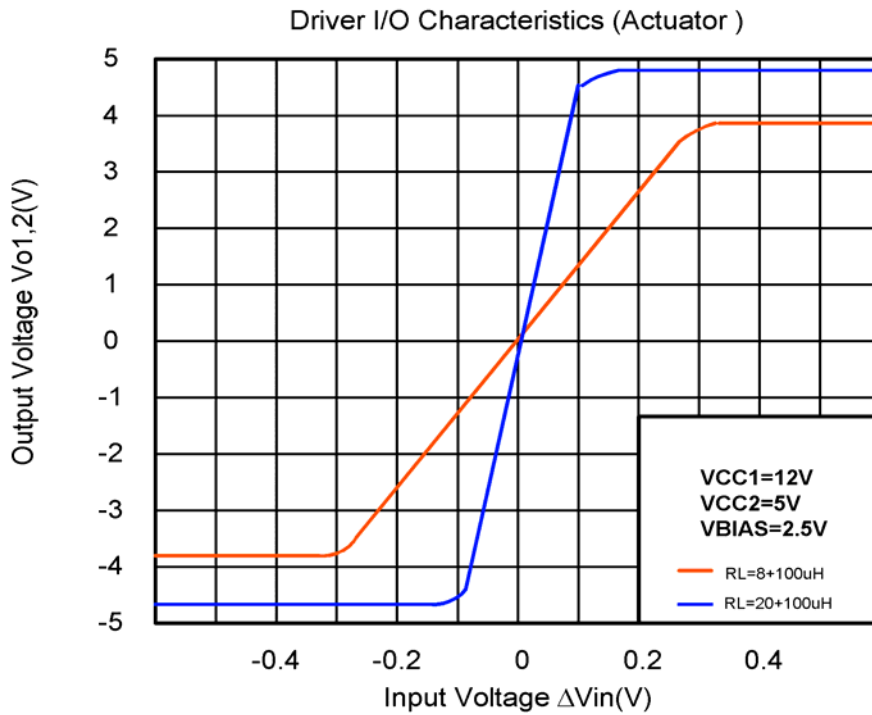

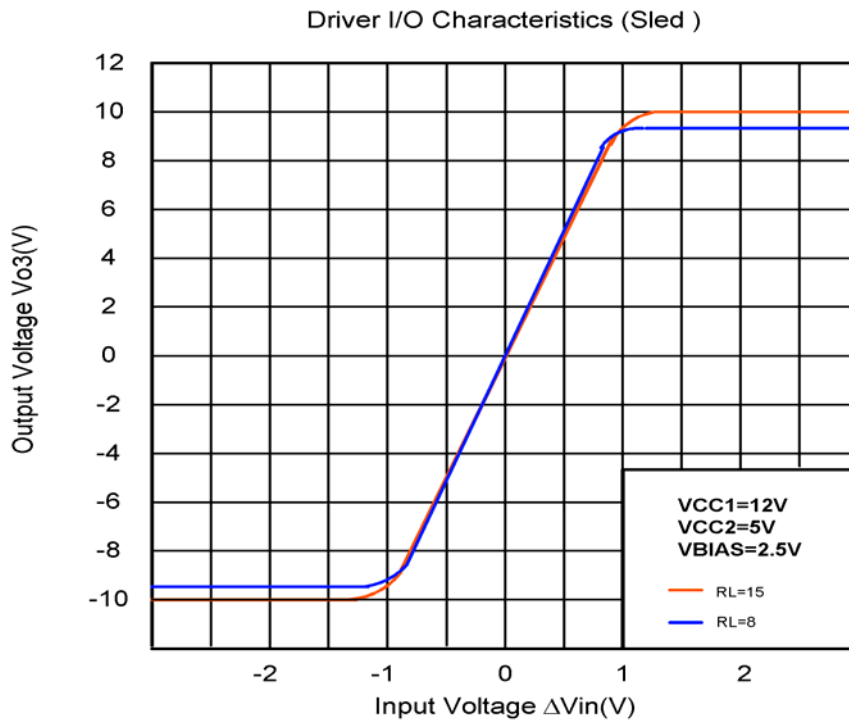
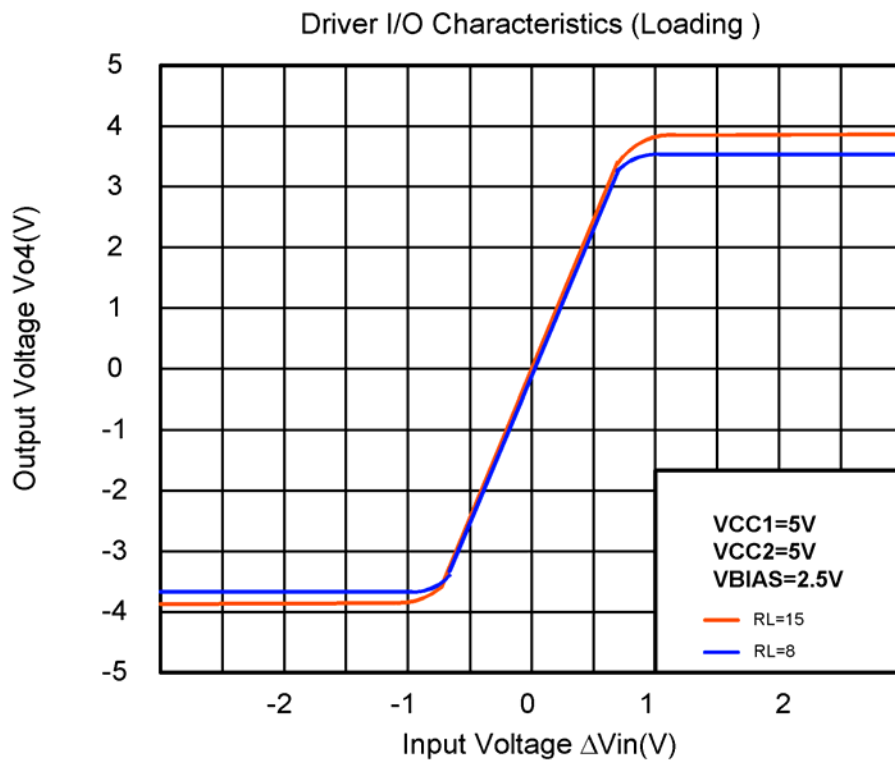



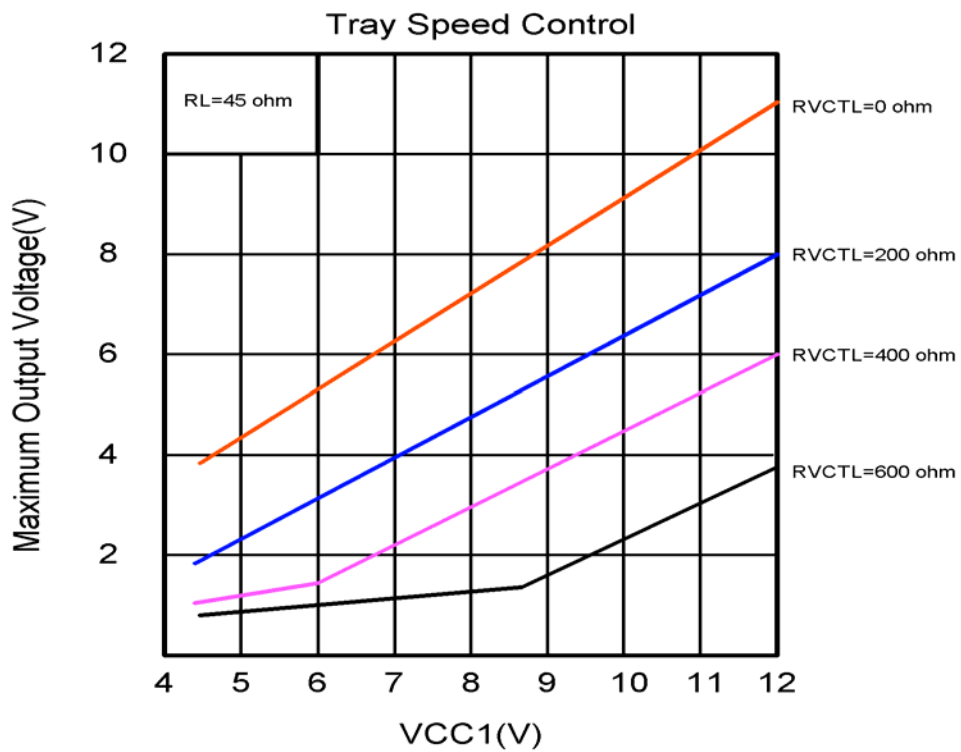
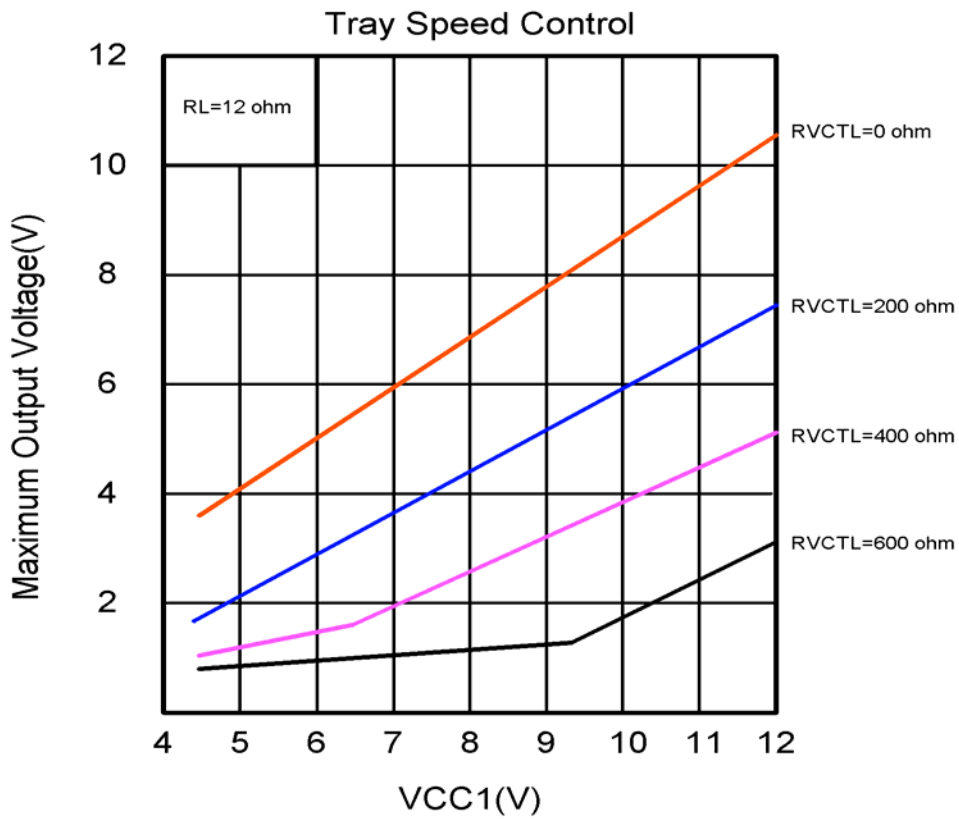

**Application circuit**

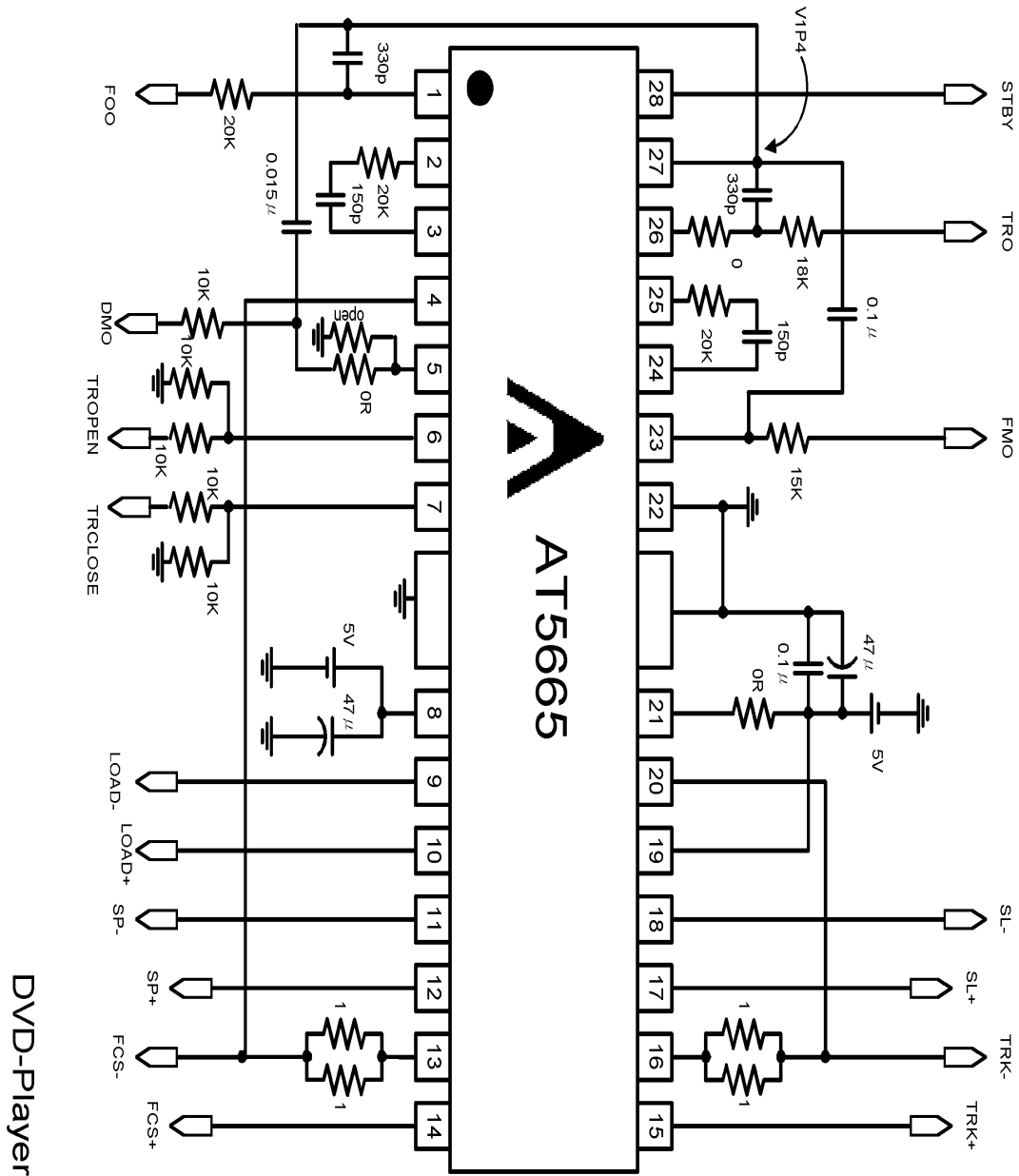

**Package Outlines (units:mm): HSOP-28**

