

TJA1054

Fault-tolerant CAN transceiver

Rev. 4 — 3 August 2010

Product data sheet

1. General description

The TJA1054 is the interface between the protocol controller and the physical bus wires in a Controller Area Network (CAN). It is primarily intended for low-speed applications up to 125 kBd in passenger cars. The device provides differential receive and transmit capability but will switch to single-wire transmitter and/or receiver in error conditions.

The TJA1054T is pin and downwards compatible with the PCA82C252T and the TJA1053T. This means that these two devices can be replaced by the TJA1054T with retention of all functions.

The most important improvements of the TJA1054 with respect to the PCA82C252 and TJA1053 are:

- Very low EME due to a very good matching of the CANL and CANH output signals
- Good EMI, especially in low power modes
- Full wake-up capability during bus failures
- Extended bus failure management including short-circuit of the CANH bus line to V_{CC}
- Support for easy system fault diagnosis
- Two-edge sensitive wake-up input signal via pin \overline{WAKE}

2. Features and benefits

2.1 Optimized for in-car low-speed communication

- Baud rate up to 125 kBd
- Up to 32 nodes can be connected
- Supports unshielded bus wires
- Very low ElectroMagnetic Emission (EME) due to built-in slope control function and a very good matching of the CANL and CANH bus outputs
- Very high ElectroMagnetic Immunity (EMI) in normal and low power operating modes
- Fully integrated receiver filters
- Transmit Data (TxD) dominant time-out function

2.2 Bus failure management

- Supports single-wire transmission modes with ground offset voltages up to 1.5 V
- Automatic switching to single-wire mode in the event of bus failures, even when the CANH bus wire is short-circuited to V_{CC}
- Automatic reset to differential mode if bus failure is removed
- Full wake-up capability during failure modes



2.3 Protections

- Bus pins short-circuit safe to battery and to ground
- Thermally protected
- Bus lines protected against transients in an automotive environment
- An unpowered node does not disturb the bus lines

2.4 Support for low power modes

- Low current sleep mode and standby mode with wake-up via the bus lines
- Power-on reset flag on the output

3. Quick reference data

Table 1. Quick reference data

$V_{CC} = 4.75\text{ V to }5.25\text{ V}$; $V_{BAT} = 5.0\text{ V to }27\text{ V}$; $V_{STB} = V_{CC}$; $T_{vj} = -40\text{ °C to }+150\text{ °C}$; all voltages are defined with respect to ground; positive currents flow into the device; unless otherwise specified. [1][2]

Symbol	Parameter	Conditions	Min	Typ	Max	Unit
V_{CC}	supply voltage		4.75	-	5.25	V
V_{BAT}	battery supply voltage on pin BAT	no time limit	-0.3	-	+40	V
		operating mode	[3] 5.0	-	27	V
		load dump	-	-	40	V
I_{BAT}	battery supply current on pin BAT	sleep mode; $V_{CC} = 0\text{ V}$; $V_{BAT} = 12\text{ V}$	-	30	50	μA
V_{CANH}	voltage on pin CANH	$V_{CC} = 0\text{ V to }5.0\text{ V}$; $V_{BAT} \geq 0\text{ V}$; no time limit; with respect to any other pin	-40	-	+40	V
V_{CANL}	voltage on pin CANL	$V_{CC} = 0\text{ V to }5.0\text{ V}$; $V_{BAT} \geq 0\text{ V}$; no time limit; with respect to any other pin	-40	-	+40	V
ΔV_{CANH}	voltage drop on pin CANH	$I_{CANH} = -40\text{ mA}$	-	-	1.4	V
ΔV_{CANL}	voltage drop on pin CANL	$I_{CANL} = 40\text{ mA}$	-	-	1.4	V
$t_{PD(L)}$	propagation delay TXD (LOW) to RXD (LOW)		-	1	-	μs
t_r	bus line output rise time	between 10 % and 90 %; $C1 = 10\text{ nF}$; see Figure 5	-	0.6	-	μs
t_f	bus line output fall time	between 10 % and 90 %; $C1 = 1\text{ nF}$; see Figure 5	-	0.3	-	μs
T_{vj}	virtual junction temperature		[4] -40	-	+150	$^{\circ}\text{C}$

[1] All parameters are guaranteed over the virtual junction temperature range by design, but only 100 % tested at $T_{amb} = 125\text{ °C}$ for dies on wafer level, and above this for cased products 100 % tested at $T_{amb} = 25\text{ °C}$, unless otherwise specified.

[2] For bare die, all parameters are only guaranteed if the back side of the die is connected to ground.

[3] A local or remote wake-up event will be signalled at the transceiver pins RXD and $\overline{\text{ERR}}$ if $V_{BAT} = 5.3\text{ V to }27\text{ V}$ see [Table 5](#).

[4] Junction temperature in accordance with "IEC 60747-1". An alternative definition is: $T_{vj} = T_{amb} + P \times R_{th(vj-a)}$ where $R_{th(vj-a)}$ is a fixed value to be used for the calculation of T_{vj} . The rating for T_{vj} limits the allowable combinations of power dissipation (P) and ambient temperature (T_{amb}).

4. Ordering information

Table 2. Ordering information

Type number	Package		Version
	Name	Description	
TJA1054T	SO14	plastic small outline package; 14 leads; body width 3.9 mm	SOT108-1
TJA1054T/S900	SO14	plastic small outline package; 14 leads; body width 3.9 mm	SOT108-1
TJA1054U	-	bare die; 1990 × 2700 × 375 μm	-

5. Block diagram

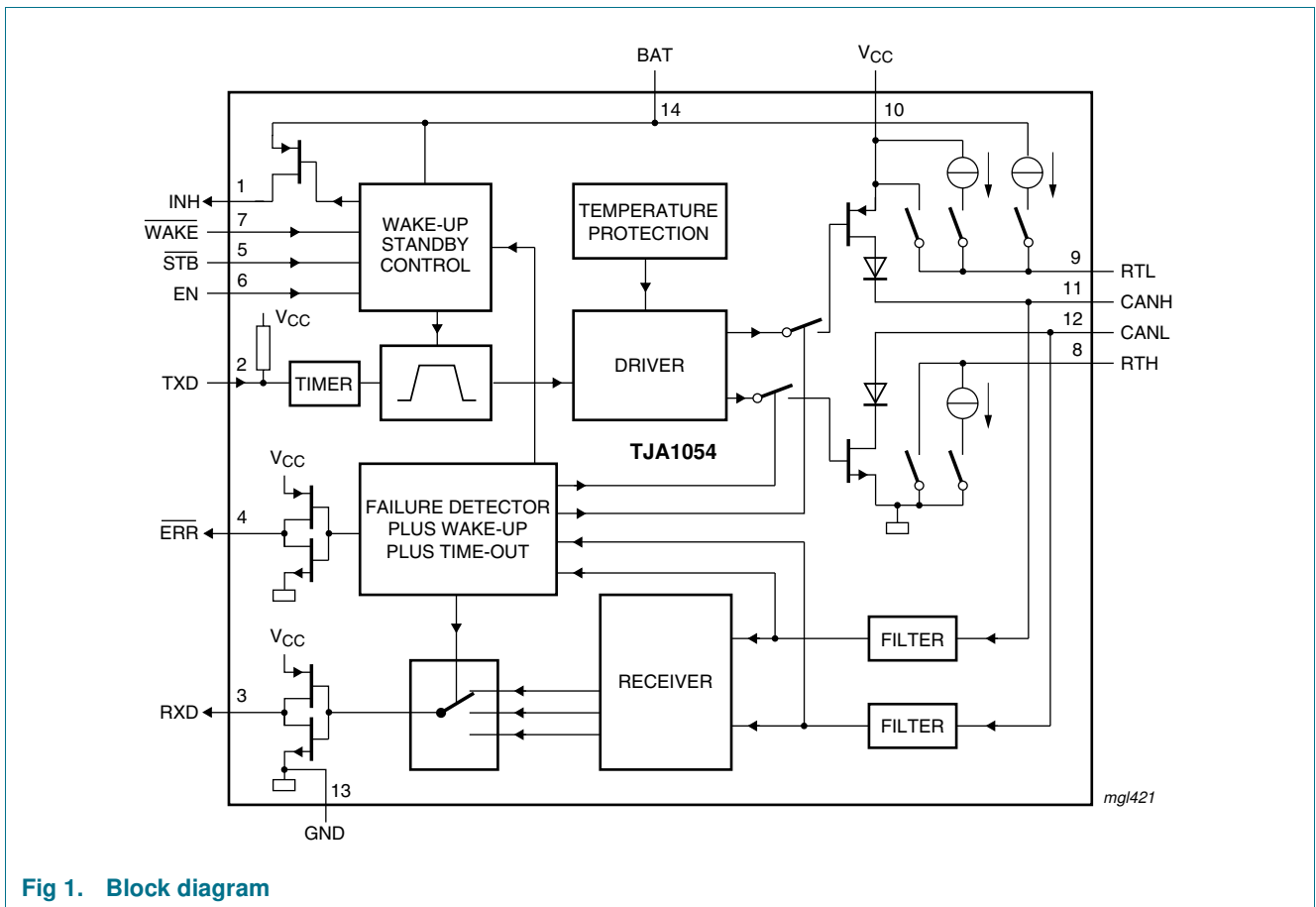

Fig 1. Block diagram

6. Pinning information

6.1 Pinning

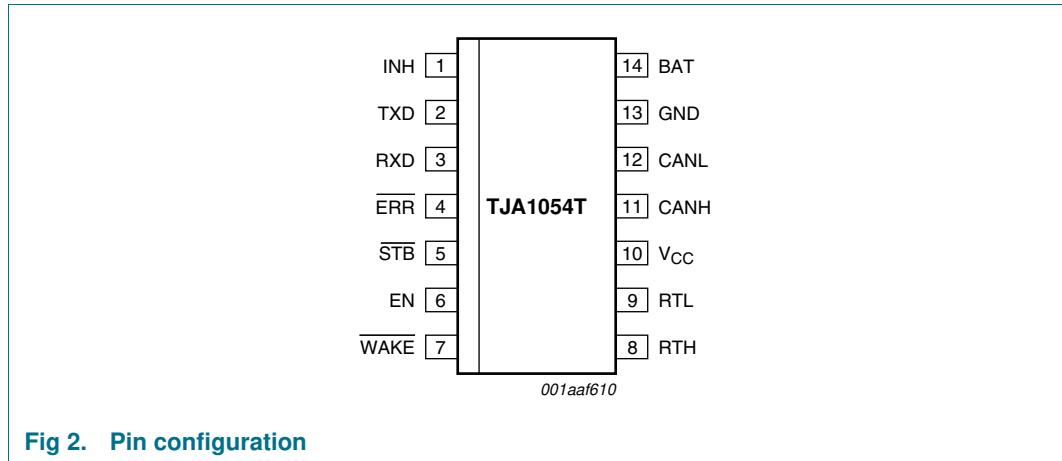

Fig 2. Pin configuration

6.2 Pin description

Table 3. Pin description

Symbol	Pin	Description
INH	1	inhibit output for switching an external voltage regulator if a wake-up signal occurs
TXD	2	transmit data input for activating the driver to the bus lines
RXD	3	receive data output for reading out the data from the bus lines
$\overline{\text{ERR}}$	4	error, wake-up and power-on indication output; active LOW in normal operating mode when a bus failure is detected; active LOW in standby and sleep mode when a wake-up is detected; active LOW in power-on standby when a V_{BAT} power-on event is detected
$\overline{\text{STB}}$	5	standby digital control signal input; together with the input signal on pin EN this input determines the state of the transceiver; see Table 5 and Figure 3
EN	6	enable digital control signal input; together with the input signal on pin $\overline{\text{STB}}$ this input determines the state of the transceiver; see Table 5 and Figure 3
$\overline{\text{WAKE}}$	7	local wake-up signal input (active LOW); both falling and rising edges are detected
RTH	8	termination resistor connection; in case of a CANH bus wire error the line is terminated with a predefined impedance
RTL	9	termination resistor connection; in case of a CANL bus wire error the line is terminated with a predefined impedance
V_{CC}	10	supply voltage
CANH	11	HIGH-level CAN bus line
CANL	12	LOW-level CAN bus line
GND	13	ground
BAT	14	battery supply voltage

7. Functional description

The TJA1054 is the interface between the CAN protocol controller and the physical wires of the CAN bus (see [Figure 7](#)). It is primarily intended for low-speed applications, up to 125 kBd, in passenger cars. The device provides differential transmit capability to the CAN bus and differential receive capability to the CAN controller.

To reduce EME, the rise and fall slopes are limited. This allows the use of an unshielded twisted pair or a parallel pair of wires for the bus lines. Moreover, the device supports transmission capability on either bus line if one of the wires is corrupted. The failure detection logic automatically selects a suitable transmission mode.

In normal operating mode (no wiring failures) the differential receiver is output on pin RXD (see [Figure 1](#)). The differential receiver inputs are connected to pins CANH and CANL through integrated filters. The filtered input signals are also used for the single-wire receivers. The receivers connected to pins CANH and CANL have threshold voltages that ensure a maximum noise margin in single-wire mode.

A timer function (TxD dominant time-out function) has been integrated to prevent the bus lines from being driven into a permanent dominant state (thus blocking the entire network communication) due to a situation in which pin TXD is permanently forced to a LOW level, caused by a hardware and/or software application failure.

If the duration of the LOW level on pin TXD exceeds a certain time, the transmitter will be disabled. The timer will be reset by a HIGH level on pin TXD.

7.1 Failure detector

The failure detector is fully active in the normal operating mode. After the detection of a single bus failure the detector switches to the appropriate mode (see [Table 4](#)). The differential receiver threshold voltage is set at -3.2 V typical ($V_{CC} = 5\text{ V}$). This ensures correct reception with a noise margin as high as possible in the normal operating mode and in the event of failures 1, 2, 5 and 6a. These failures, or recovery from them, do not destroy ongoing transmissions. The output drivers remain active, the termination does not change and the receiver remains in differential mode (see [Table 4](#)).

Failures 3, 3a and 6 are detected by comparators connected to the CANH and CANL bus lines. Failures 3 and 3a are detected in a two-step approach. If the CANH bus line exceeds a certain voltage level, the differential comparator signals a continuous dominant condition. Because of inter operability reasons with the predecessor products PCA82C252 and TJA1053, after a first time-out the transceiver switches to single-wire operation through CANH. If the CANH bus line is still exceeding the CANH detection voltage for a second time-out, the TJA1054 switches to CANL operation; the CANH driver is switched off and the RTH bias changes to the pull-down current source. The time-outs (delays) are needed to avoid false triggering by external RF fields.

Table 4. Bus failures

Failure	Description	Termination CANH (RTH)	Termination CANL (RTL)	CANH driver	CANL driver	Receiver mode
1	CANH wire interrupted	on	on	on	on	differential
2	CANL wire interrupted	on	on	on	on	differential
3	CANH short-circuited to battery	weak ^[1]	on	off	on	CANL
3a	CANH short-circuited to V _{CC}	weak ^[1]	on	off	on	CANL
4	CANL short-circuited to ground	on	weak ^[2]	on	off	CANH
5	CANH short-circuited to ground	on	on	on	on	differential
6	CANL short-circuited to battery	on	weak ^[2]	on	off	CANH
6a	CANL short-circuited to V _{CC}	on	on	on	on	differential
7	CANL and CANH mutually short-circuited	on	weak ^[2]	on	off	CANH

[1] A weak termination implies a pull-down current source behavior of 75 μ A typical.

[2] A weak termination implies a pull-up current source behavior of 75 μ A typical.

Failure 6 is detected if the CANL bus line exceeds its comparator threshold for a certain period of time. This delay is needed to avoid false triggering by external RF fields. After detection of failure 6, the reception is switched to the single-wire mode through CANH; the CANL driver is switched off and the RTL bias changes to the pull-up current source.

Recovery from failures 3, 3a and 6 is detected automatically after reading a consecutive recessive level by corresponding comparators for a certain period of time.

Failures 4 and 7 initially result in a permanent dominant level on pin RXD. After a time-out the CANL driver is switched off and the RTL bias changes to the pull-up current source. Reception continues by switching to the single-wire mode via pins CANH or CANL. When failures 4 or 7 are removed, the recessive bus levels are restored. If the differential voltage remains below the recessive threshold level for a certain period of time, reception and transmission switch back to the differential mode.

If any of the wiring failure occurs, the output signal on pin $\overline{\text{ERR}}$ will be set to LOW. On error recovery, the output signal on pin $\overline{\text{ERR}}$ will be set to HIGH again. In case of an interrupted open bus wire, this failure will be detected and signalled only if there is an open wire between the transmitting and receiving node(s). Thus, during open wire failures, pin $\overline{\text{ERR}}$ typically toggles.

During all single-wire transmissions, EMC performance (both immunity and emission) is worse than in the differential mode. The integrated receiver filters suppress any HF noise induced into the bus wires. The cut-off frequency of these filters is a compromise between propagation delay and HF suppression. In single-wire mode, LF noise cannot be distinguished from the required signal.

7.2 Low power modes

The transceiver provides three low power modes which can be entered and exited via $\overline{\text{STB}}$ and EN (see [Table 5](#) and [Figure 3](#)).

The sleep mode is the mode with the lowest power consumption. Pin INH is switched to HIGH-impedance for deactivation of the external voltage regulator. Pin CANL is biased to the battery voltage via pin RTL. If the supply voltage is provided, pins RXD and $\overline{\text{ERR}}$ will signal the wake-up interrupt.

The standby mode operates in the same way as the sleep mode but with a HIGH level on pin INH.

The power-on standby mode is the same as the standby mode, however, in this mode the battery power-on flag is shown on pin $\overline{\text{ERR}}$ instead of the wake-up interrupt signal. The output on pin RXD will show the wake-up interrupt. This mode is only for reading out the power-on flag.

Table 5. Normal operating and low power modes

Mode	Pin STB	Pin EN	Pin ERR		Pin RXD		Pin RTL switched to
			LOW	HIGH	LOW	HIGH	
Goto-sleep command	LOW	HIGH	wake-up interrupt signal ^{[1][2][3]}		wake-up interrupt signal ^{[1][2][3]}		V_{BAT}
Sleep	LOW	LOW ^[4]					
Standby	LOW	LOW					
Power-on standby	HIGH	LOW	V_{BAT} power-on flag ^{[1][5]}		wake-up interrupt signal ^{[1][2][3]}		V_{BAT}
Normal operating	HIGH	HIGH	error flag	no error flag	dominant received data	recessive received data	V_{CC}

[1] If the supply voltage V_{CC} is present

[2] Wake-up interrupts are released when entering normal operating mode.

[3] A local or remote wake-up event will be signalled at the transceiver pins RXD and $\overline{\text{ERR}}$ if $V_{\text{BAT}} = 5.3 \text{ V to } 27 \text{ V}$.

[4] In case the goto-sleep command was used before. When V_{CC} drops, pin EN will become LOW, but due to the fail-safe functionality this does not effect the internal functions.

[5] V_{BAT} power-on flag will be reset when entering normal operating mode.

Wake-up requests are recognized by the transceiver through two possible channels:

- The bus lines for remote wake-up
- Pin $\overline{\text{WAKE}}$ for local wake-up

In order to wake-up the transceiver remotely through the bus lines, a filter mechanism is integrated. This mechanism makes sure that noise and any present bus failure conditions do not result into an erroneous wake-up. Because of this mechanism it is not sufficient to simply pull the CANH or CANL bus lines to a dominant level for a certain time. To guarantee a successful remote wake-up under all conditions, a message frame with a dominant phase of at least the maximum specified $t_{(\text{CANH})}$ or $t_{(\text{CANL})}$ in it is required.

A local wake-up through pin $\overline{\text{WAKE}}$ is detected by a rising or falling edge with a consecutive level exceeding the maximum specified t_{WAKE} .

On a wake-up request the transceiver will set the output on pin INH to HIGH which can be used to activate the external supply voltage regulator.

If V_{CC} is provided the wake-up request can be read on the $\overline{\text{ERR}}$ or RXD outputs, so the external microcontroller can activate the transceiver (switch to normal operating mode) via pins STB and EN.

To prevent a false remote wake-up due to transients or RF fields, the wake-up voltage levels have to be maintained for a certain period of time. In the low power modes the failure detection circuit remains partly active to prevent an increased power consumption in the event of failures 3, 3a, 4 and 7.

To prevent a false local wake-up during an open wire at pin $\overline{\text{WAKE}}$, this pin has a weak pull-up current source towards V_{BAT} . However, in order to prevent EMC issues, it is recommended to connect a not used pin $\overline{\text{WAKE}}$ to pin BAT. INH is set to floating only if the goto-sleep command is entered successfully. To enter a successful goto-sleep command under all conditions, this command must be kept stable for the maximum specified $t_{\text{h(sleep)}}$.

Pin INH will be set to a HIGH level again by the following events only:

- V_{BAT} power-on (cold start)
- Rising or falling edge on pin $\overline{\text{WAKE}}$
- A message frame with a dominant phase of at least the maximum specified $t_{\text{(CANH)}}$ or $t_{\text{(CANL)}}$, while pin EN or pin $\overline{\text{STB}}$ is at a LOW level
- Pin $\overline{\text{STB}}$ goes to a HIGH level with V_{CC} active

To provide fail-safe functionality, the signals on pins $\overline{\text{STB}}$ and EN will internally be set to LOW when V_{CC} is below a certain threshold voltage ($V_{\text{CC(stb)}}$).

7.3 Power-on

After power-on (V_{BAT} switched on) the signal on pin INH will become HIGH and an internal power-on flag will be set. This flag can be read in the power-on standby mode through pin $\overline{\text{ERR}}$ ($\overline{\text{STB}} = 1$; EN = 0) and will be reset by entering the normal operating mode.

7.4 Protections

A current limiting circuit protects the transmitter output stages against short-circuit to positive and negative battery voltage.

If the junction temperature exceeds the typical value of 165 °C, the transmitter output stages are disabled. Because the transmitter is responsible for the major part of the power dissipation, this will result in a reduced power dissipation and hence a lower chip temperature. All other parts of the device will continue to operate.

The pins CANH and CANL are protected against electrical transients which may occur in an automotive environment.

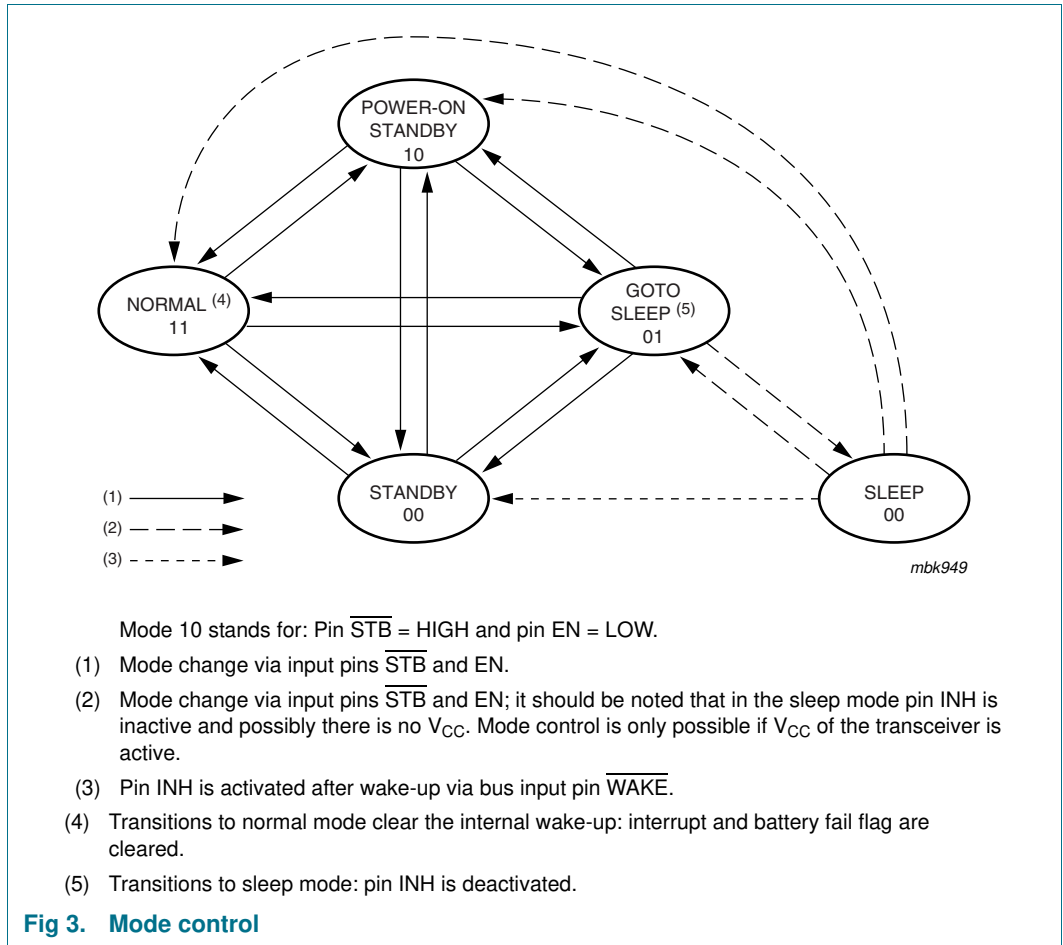

8. Limiting values

Table 6. Limiting values

In accordance with the Absolute Maximum Rating System (IEC 60134).[\[1\]](#)

Symbol	Parameter	Conditions	Min	Max	Unit
V_{CC}	supply voltage		-0.3	+6	V
V_{BAT}	battery supply voltage		-0.3	+40	V
V_{TXD}	voltage on pin TXD		-0.3	$V_{CC} + 0.3$	V
V_{RXD}	voltage on pin RXD		-0.3	$V_{CC} + 0.3$	V
V_{ERR}	voltage on pin \overline{ERR}		-0.3	$V_{CC} + 0.3$	V
V_{STB}	voltage on pin \overline{STB}		-0.3	$V_{CC} + 0.3$	V
V_{EN}	voltage on pin EN		-0.3	$V_{CC} + 0.3$	V
V_{CANH}	voltage on pin CANH	with respect to any other pin	-40	+40	V
V_{CANL}	voltage on pin CANL	with respect to any other pin	-40	+40	V
$V_{trt(n)}$	transient voltage on pins CANH and CANL	see Figure 6	-150	+100	V

Table 6. Limiting values ...continued
 In accordance with the Absolute Maximum Rating System (IEC 60134).^[1]

Symbol	Parameter	Conditions	Min	Max	Unit
$V_{I(WAKE)}$	input voltage on pin \overline{WAKE}	with respect to any other pin	–	$V_{BAT} + 0.3$	V
$I_{I(WAKE)}$	input current on pin \overline{WAKE}		^[2] –15	–	mA
V_{INH}	voltage on pin INH		–0.3	$V_{BAT} + 0.3$	V
V_{RTH}	voltage on pin RTH	with respect to any other pin	–0.3	$V_{BAT} + 1.2$	V
V_{RTL}	voltage on pin RTL	with respect to any other pin	–0.3	$V_{BAT} + 1.2$	V
R_{RTH}	termination resistance on pin RTH		500	16000	Ω
R_{RTL}	termination resistance on pin RTL		500	16000	Ω
T_{vj}	virtual junction temperature		^[3] –40	+150	$^{\circ}\text{C}$
T_{stg}	storage temperature		–55	+150	$^{\circ}\text{C}$
V_{ESD}	electrostatic discharge voltage	human body model	^[4] –2	+2	kV
		machine model	^[5] –100	+100	V

[1] All voltages are defined with respect to pin GND, unless otherwise specified. Positive current flows into the device.

[2] Only relevant if $V_{WAKE} < V_{GND} - 0.3$ V; current will flow into pin GND.

[3] Junction temperature in accordance with "IEC 60747-1". An alternative definition is: $T_{vj} = T_{amb} + P \times R_{th(vj-a)}$ where $R_{th(vj-a)}$ is a fixed value to be used for the calculation of T_{vj} . The rating for T_{vj} limits the allowable combinations of power dissipation (P) and ambient temperature (T_{amb}).

[4] Equivalent to discharging a 100 pF capacitor through a 1.5 k Ω resistor.

[5] Equivalent to discharging a 200 pF capacitor through a 10 Ω resistor and a 0.75 μH coil.

9. Thermal characteristics

Table 7. Thermal characteristics

Symbol	Parameter	Conditions	Typ	Unit
$R_{th(j-a)}$	thermal resistance from junction to ambient	in free air	120	K/W
$R_{th(j-s)}$	thermal resistance from junction to substrate bare die	in free air	40	K/W

10. Static characteristics

Table 8. Static characteristics

$V_{CC} = 4.75\text{ V to }5.25\text{ V}$; $V_{BAT} = 5.0\text{ V to }27\text{ V}$; $V_{STB} = V_{CC}$; $T_{vj} = -40\text{ }^{\circ}\text{C to }+150\text{ }^{\circ}\text{C}$; all voltages are defined with respect to ground; positive currents flow into the device; unless otherwise specified. [\[1\]](#)[\[2\]](#)[\[3\]](#)

Symbol	Parameter	Conditions	Min	Typ	Max	Unit
Supplies (pins V_{CC} and BAT)						
V_{CC}	supply voltage		4.75	-	5.25	V
$V_{CC(stb)}$	supply voltage for forced standby mode (fail-safe)		2.75	-	4.5	V
I_{CC}	supply current	normal operating mode; $V_{TXD} = V_{CC}$ (recessive)	4	7	11	mA
		normal operating mode; $V_{TXD} = 0\text{ V}$ (dominant); no load	10	17	27	mA
		low power modes at $V_{TXD} = V_{CC}$	0	0	10	μA
V_{BAT}	battery supply voltage on pin BAT	no time limit	-0.3	-	+40	V
		operating mode	5.0	-	27	V
		load dump	-	-	40	V
I_{BAT}	battery supply current on pin BAT	all modes and in low power modes at $V_{RTL} = V_{WAKE} = V_{INH} = V_{BAT}$				
		$V_{BAT} = 12\text{ V}$	10	30	50	μA
		$V_{BAT} = 5\text{ V to }27\text{ V}$	5	30	125	μA
		$V_{BAT} = 3.5\text{ V}$	5	20	30	μA
		$V_{BAT} = 1\text{ V}$	0	0	10	μA
		sleep mode; $V_{CC} = 0\text{ V}$; $V_{BAT} = 12\text{ V}$	-	30	50	μA
$V_{BAT(Pwon)}$	power-on flag voltage on pin BAT	low power modes				
		power-on flag set	-	-	1	V
		power-on flag not set	3.5	-	-	V
I_{tot}	supply current plus battery current	low power modes; $V_{CC} = 5\text{ V}$; $V_{BAT} = V_{WAKE} = V_{INH} = 12\text{ V}$	-	30	60	μA
Pins \overline{STB}, EN and TXD						
V_{IH}	HIGH-level input voltage		$0.7V_{CC}$	-	$V_{CC} + 0.3$	V
V_{IL}	LOW-level input voltage		-0.3	-	$0.3V_{CC}$	V
I_{IH}	HIGH-level input current	pins \overline{STB} and EN $V_I = 4\text{ V}$	-	9	20	μA
		pin TXD $V_I = 4\text{ V}$	-200	-80	-25	μA
I_{IL}	LOW-level input current	pins \overline{STB} and EN $V_I = 1\text{ V}$	4	8	-	μA
		pin TXD $V_I = 1\text{ V}$	-800	-320	-100	μA

Table 8. Static characteristics ...continued

$V_{CC} = 4.75\text{ V to }5.25\text{ V}$; $V_{BAT} = 5.0\text{ V to }27\text{ V}$; $V_{STB} = V_{CC}$; $T_{vj} = -40\text{ }^{\circ}\text{C to }+150\text{ }^{\circ}\text{C}$; all voltages are defined with respect to ground; positive currents flow into the device; unless otherwise specified. [\[1\]\[2\]\[3\]](#)

Symbol	Parameter	Conditions	Min	Typ	Max	Unit	
Pins RXD and ERR							
V_{OH}	HIGH-level output voltage						
		on pin $\overline{\text{ERR}}$	$I_O = -100\ \mu\text{A}$	$V_{CC} - 0.9$	-	V_{CC}	V
		on pin RXD	$I_O = -1\text{ mA}$	$V_{CC} - 0.9$	-	V_{CC}	V
V_{OL}	LOW-level output voltage						
		on pin $\overline{\text{ERR}}$	$I_O = 1.6\text{ mA}$	0	-	0.4	V
		on pin RXD	$I_O = 7.5\text{ mA}$	0	-	1.5	V
Pin WAKE							
I_{IL}	LOW-level input current	$V_{WAKE} = 0\text{ V}$; $V_{BAT} = 27\text{ V}$	-10	-4	-1	μA	
$V_{th(wake)}$	wake-up threshold voltage	$V_{STB} = 0\text{ V}$	2.5	3.2	3.9	V	
Pin INH							
ΔV_H	HIGH-level voltage drop	$I_{INH} = -0.18\text{ mA}$	-	-	0.8	V	
I_L	leakage current	sleep mode; $V_{INH} = 0\text{ V}$	-	-	5	μA	
Pins CANH and CANL							
V_{CANH}	voltage on pin CANH	$V_{CC} = 0\text{ V to }5.0\text{ V}$; $V_{BAT} \geq 0\text{ V}$; no time limit; with respect to any other pin	-40	-	+40	V	
V_{CANL}	voltage on pin CANL	$V_{CC} = 0\text{ V to }5.0\text{ V}$; $V_{BAT} \geq 0\text{ V}$; no time limit; with respect to any other pin	-40	-	+40	V	
ΔV_{CANH}	voltage drop on pin CANH	$I_{CANH} = -40\text{ mA}$	-	-	1.4	V	
ΔV_{CANL}	voltage drop on pin CANL	$I_{CANL} = 40\text{ mA}$	-	-	1.4	V	
$V_{th(dif)}$	differential receiver threshold voltage	no failures and bus failures 1, 2, 5 and 6a; see Figure 4					
		$V_{CC} = 5\text{ V}$	-3.5	-3.2	-2.9	V	
		$V_{CC} = 4.75\text{ V to }5.25\text{ V}$	$-0.70V_{CC}$	$-0.64V_{CC}$	$-0.58V_{CC}$	V	
$V_{O(reces)}$	recessive output voltage	$V_{TXD} = V_{CC}$					
		on pin CANH	$R_{RTH} < 4\text{ k}\Omega$	-	-	0.2	V
		on pin CANL	$R_{RTL} < 4\text{ k}\Omega$	$V_{CC} - 0.2$	-	-	V
$V_{O(dom)}$	dominant output voltage	$V_{TXD} = 0\text{ V}$; $V_{EN} = V_{CC}$					
		on pin CANH	$I_{CANH} = -40\text{ mA}$	$V_{CC} - 1.4$	-	-	V
		on pin CANL	$I_{CANL} = 40\text{ mA}$	-	-	1.4	V
$I_{O(CANH)}$	output current on pin CANH	normal operating mode; $V_{CANH} = 0\text{ V}$; $V_{TXD} = 0\text{ V}$	-110	-80	-45	mA	
		low power modes; $V_{CANH} = 0\text{ V}$; $V_{CC} = 5\text{ V}$	-	-0.25	-	μA	

Table 8. Static characteristics ...continued

$V_{CC} = 4.75\text{ V to }5.25\text{ V}$; $V_{BAT} = 5.0\text{ V to }27\text{ V}$; $V_{STB} = V_{CC}$; $T_{vj} = -40\text{ }^{\circ}\text{C to }+150\text{ }^{\circ}\text{C}$; all voltages are defined with respect to ground; positive currents flow into the device; unless otherwise specified. [\[1\]](#)[\[2\]](#)[\[3\]](#)

Symbol	Parameter	Conditions	Min	Typ	Max	Unit
$I_{O(CANL)}$	output current on pin CANL	normal operating mode; $V_{CANL} = 14\text{ V}$; $V_{TXD} = 0\text{ V}$	45	70	100	mA
		low power modes; $V_{CANL} = 12\text{ V}$; $V_{BAT} = 12\text{ V}$	-	0	-	μA
$V_{d(CANH)(sc)}$	detection voltage for short-circuit to battery voltage on pin CANH	normal operating mode; $V_{CC} = 5\text{ V}$	1.5	1.7	1.85	V
		low power modes	1.1	1.8	2.5	V
$V_{d(CANL)(sc)}$	detection voltage for short-circuit to battery voltage on pin CANL	normal operating mode $V_{CC} = 5\text{ V}$	6.6	7.2	7.8	V
		$V_{CC} = 4.75\text{ V to }5.25\text{ V}$	$1.32V_{CC}$	$1.44V_{CC}$	$1.56V_{CC}$	V
$V_{th(wake)}$	wake-up threshold voltage	on pin CANL	2.5	3.2	3.9	V
		on pin CANH	1.1	1.8	2.5	V
$\Delta V_{th(wake)}$	difference of wake-up threshold voltages	low power modes	0.8	1.4	-	V
$V_{th(CANH)(sc)}$	single-ended receiver threshold voltage on pin CANH	normal operating mode and failures 4, 6 and 7 $V_{CC} = 5\text{ V}$	1.5	1.7	1.85	V
		$V_{CC} = 4.75\text{ V to }5.25\text{ V}$	$0.30V_{CC}$	$0.34V_{CC}$	$0.37V_{CC}$	V
$V_{th(CANL)(sc)}$	single-ended receiver threshold voltage on pin CANL	normal operating mode and failures 3 and 3a $V_{CC} = 5\text{ V}$	3.15	3.3	3.45	V
		$V_{CC} = 4.75\text{ V to }5.25\text{ V}$	$0.63V_{CC}$	$0.66V_{CC}$	$0.69V_{CC}$	V
$R_{i(CANH)(sc)}$	single-ended input resistance on pin CANH	normal operating mode	110	165	270	k Ω
$R_{i(CANL)(sc)}$	single-ended input resistance on pin CANL	normal operating mode	110	165	270	k Ω
$R_{i(dif)}$	differential input resistance	normal operating mode	220	330	540	k Ω
Pins RTH and RTL						
$R_{sw(RTL)}$	switch-on resistance on pin RTL and V_{CC}	normal operating mode; $ I_O < 10\text{ mA}$	-	50	100	Ω
$R_{sw(RTH)}$	switch-on resistance on pin RTH and ground	normal operating mode; $ I_O < 10\text{ mA}$	-	50	100	Ω
$V_{O(RTH)}$	output voltage on pin RTH	low power modes; $I_O = 1\text{ mA}$	-	0.7	1.0	V
$I_{O(RTL)}$	output current on pin RTL	low power modes; $V_{RTL} = 0\text{ V}$	-1.25	-0.65	-0.3	mA
$I_{pu(RTL)}$	pull-up current on pin RTL	normal operating mode and failures 4, 6 and 7	-	75	-	μA

Table 8. Static characteristics ...continued

$V_{CC} = 4.75\text{ V to }5.25\text{ V}$; $V_{BAT} = 5.0\text{ V to }27\text{ V}$; $V_{STB} = V_{CC}$; $T_{vj} = -40\text{ }^{\circ}\text{C to }+150\text{ }^{\circ}\text{C}$; all voltages are defined with respect to ground; positive currents flow into the device; unless otherwise specified. [\[1\]](#)[\[2\]](#)[\[3\]](#)

Symbol	Parameter	Conditions	Min	Typ	Max	Unit
$I_{pd(RTH)}$	pull-down current on pin RTH	normal operating mode and failures 3 and 3a	-	75	-	μA
Thermal shutdown						
$T_{j(sd)}$	shutdown junction temperature		155	165	180	$^{\circ}\text{C}$

- [1] All parameters are guaranteed over the virtual junction temperature range by design, but only 100 % tested at $T_{amb} = 125\text{ }^{\circ}\text{C}$ for dies on wafer level, and above this for cased products 100 % tested at $T_{amb} = 25\text{ }^{\circ}\text{C}$, unless otherwise specified.
- [2] For bare die, all parameters are only guaranteed if the back side of the die is connected to ground.
- [3] A local or remote wake-up event will be signalled at the transceiver pins RXD and $\overline{\text{ERR}}$ if $V_{BAT} = 5.3\text{ V to }27\text{ V}$ (see [Table 5](#)).

11. Dynamic characteristics

Table 9. Dynamic characteristics

$V_{CC} = 4.75\text{ V to }5.25\text{ V}$; $V_{BAT} = 5.0\text{ V to }27\text{ V}$; $V_{STB} = V_{CC}$; $T_{vj} = -40\text{ }^{\circ}\text{C to }+150\text{ }^{\circ}\text{C}$; all voltages are defined with respect to ground; unless otherwise specified. [\[1\]](#)[\[2\]](#)[\[3\]](#)

Symbol	Parameter	Conditions	Min	Typ	Max	Unit
$t_{t(r-d)}$	transition time for recessive to dominant (on pins CANL and CANH)	between 10 % and 90 %; $R1 = 100\ \Omega$; $C1 = 10\text{ nF}$; $C2 = \text{not present}$; see Figure 5	0.35	0.65	-	μs
$t_{t(d-r)}$	transition time for dominant to recessive (on pins CANL and CANH)	between 10 % and 90 %; $R1 = 100\ \Omega$; $C1 = 10\text{ nF}$; $C2 = \text{not present}$; see Figure 5	0.2	0.3	-	μs
$t_{PD(L)}$	propagation delay TXD (LOW) to RXD (LOW)	no failures and failures 1, 2, 5 and 6a; $R1 = 100\ \Omega$; see Figure 4 and Figure 5	-	0.75	1.5	μs
		$C1 = 1\text{ nF}$; $C2 = \text{not present}$	-	1	1.75	μs
		$C1 = C2 = 3.3\text{ nF}$	-	1.1	1.7	μs
		failures 3, 3a, 4, 6 and 7; $R1 = 100\ \Omega$; see Figure 4 and Figure 5	-	0.85	1.4	μs
		$C1 = 1\text{ nF}$; $C2 = \text{not present}$	-	1.1	1.7	μs
$t_{PD(H)}$	propagation delay TXD (HIGH) to RXD (HIGH)	no failures and failures 1, 2, 5 and 6a; $R1 = 100\ \Omega$; see Figure 4 and Figure 5	-	1.2	1.9	μs
		$C1 = 1\text{ nF}$; $C2 = \text{not present}$	-	2.5	3.3	μs
		$C1 = C2 = 3.3\text{ nF}$	-	1.1	1.7	μs
		failures 3, 3a, 4, 6 and 7; $R1 = 100\ \Omega$; see Figure 4 and Figure 5	-	1.5	2.2	μs
		$C1 = 1\text{ nF}$; $C2 = \text{not present}$	-	1.5	2.2	μs
t_r	bus line output rise time	between 10 % and 90 %; $C1 = 10\text{ nF}$; see Figure 5	-	0.6	-	μs
t_f	bus line output fall time	between 10 % and 90 %; $C1 = 1\text{ nF}$; see Figure 5	-	0.3	-	μs
$t_{react(sleep)}$	reaction time of goto sleep command		[4] 5	-	50	μs

Table 9. Dynamic characteristics ...continued

$V_{CC} = 4.75\text{ V to }5.25\text{ V}$; $V_{BAT} = 5.0\text{ V to }27\text{ V}$; $V_{STB} = V_{CC}$; $T_{vj} = -40\text{ °C to }+150\text{ °C}$; all voltages are defined with respect to ground; unless otherwise specified. [\[1\]](#)[\[2\]](#)[\[3\]](#)

Symbol	Parameter	Conditions	Min	Typ	Max	Unit
$t_{dis(TxD)}$	disable time of TxD permanent dominant timer	normal operating mode; $V_{TXD} = 0\text{ V}$	0.75	-	4	ms
t_{CANH}	dominant time for remote wake-up on pin CANH	low power modes; $V_{BAT} = 12\text{ V}$	[4] 7	-	38	μs
t_{CANL}	dominant time for remote wake-up on pin CANL	low power modes; $V_{BAT} = 12\text{ V}$	[4] 7	-	38	μs
t_{WAKE}	required time on pin WAKE for local wake-up	low power modes; $V_{BAT} = 12\text{ V}$; for wake-up after receiving a falling or rising edge	[4] 7	-	38	μs
t_{det}	failure detection time	normal operating mode				
		failures 3 and 3a	1.6	-	8.0	ms
		failures 4, 6 and 7	0.3	-	1.6	ms
		low power modes; $V_{BAT} = 12\text{ V}$				
		failures 3 and 3a	1.6	-	8.0	ms
		failures 4 and 7	0.1	-	1.6	ms
t_{rec}	failure recovery time	normal operating mode				
		failures 3 and 3a	0.3	-	1.6	ms
		failures 4 and 7	7	-	38	μs
		failure 6	125	-	750	μs
		low power modes; $V_{BAT} = 12\text{ V}$				
		failures 3, 3a, 4 and 7	0.3	-	1.6	ms
n_{det}	pulse-count difference between CANH and CANL for failure detection	normal operating mode and failures 1, 2, 5 and 6a; pin ERR becomes LOW	-	4	-	
n_{rec}	number of consecutive pulses on CANH and CANL simultaneously for failure recovery	failures 1, 2, 5 and 6a	-	4	-	

[1] All parameters are guaranteed over the virtual junction temperature range by design, but only 100 % tested at $T_{amb} = 125\text{ °C}$ for dies on wafer level, and above this for cased products 100 % tested at $T_{amb} = 25\text{ °C}$, unless otherwise specified.

[2] For bare die, all parameters are only guaranteed if the back side of the die is connected to ground.

[3] A local or remote wake-up event will be signalled at the transceiver pins RXD and $\overline{\text{ERR}}$ if $V_{BAT} = 5.3\text{ V to }27\text{ V}$ (see [Table 5](#)).

[4] To guarantee a successful mode transition under all conditions, the maximum specified time must be applied.

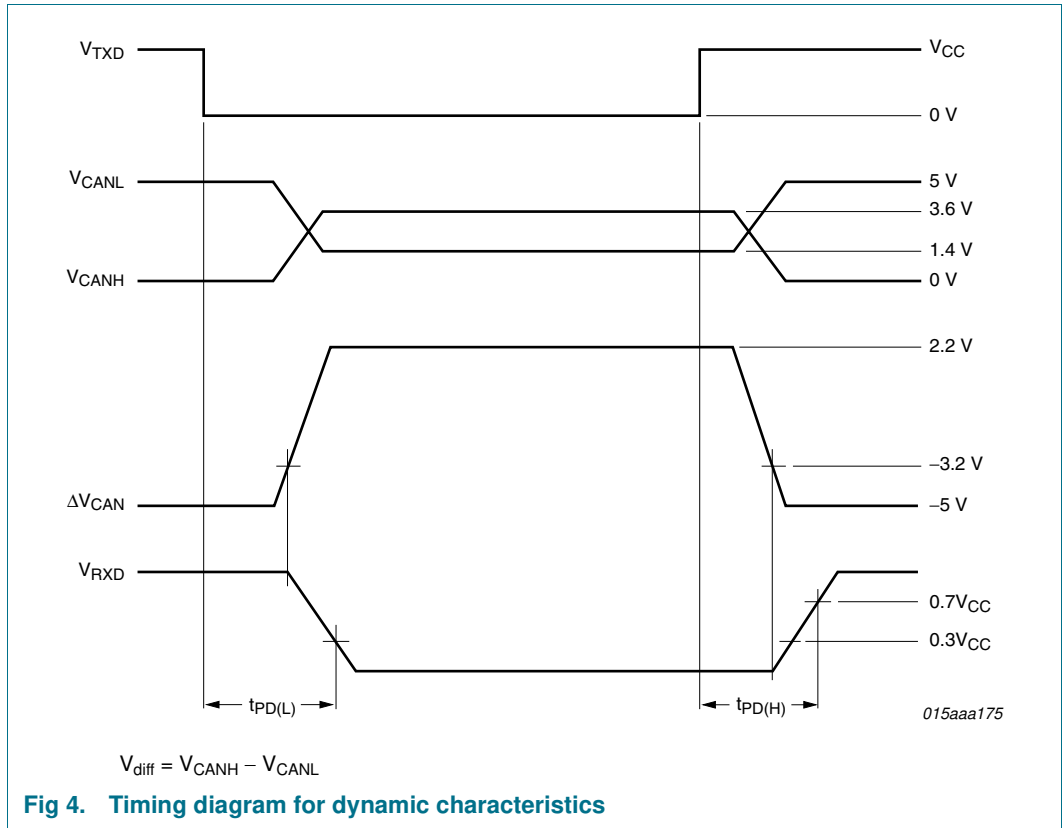

12. Test information

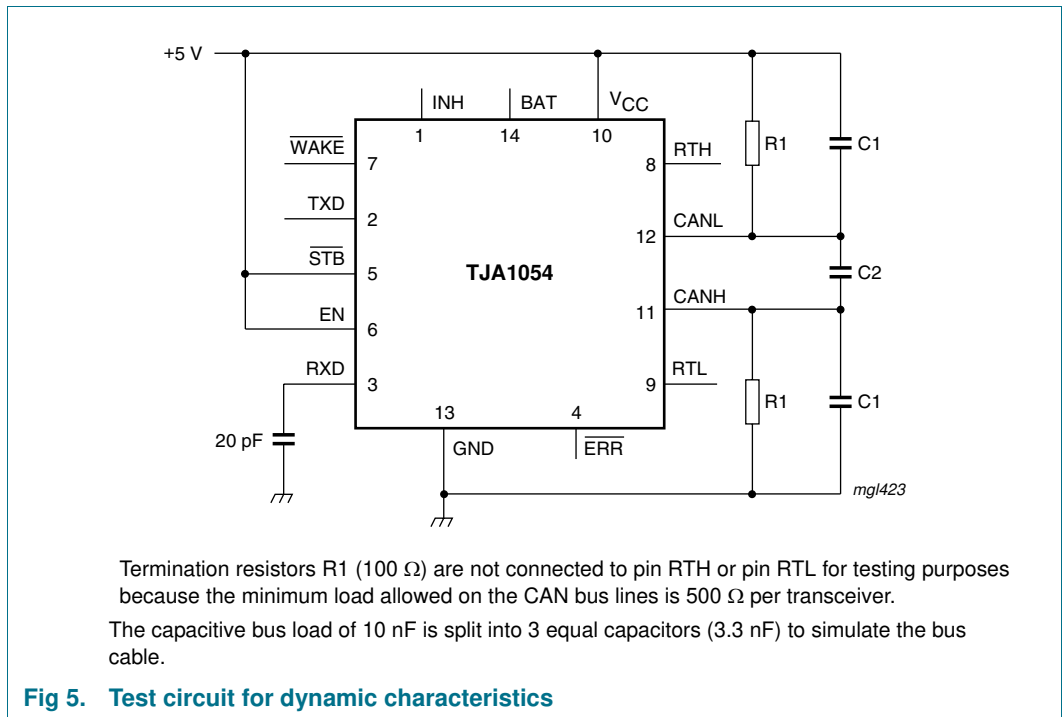

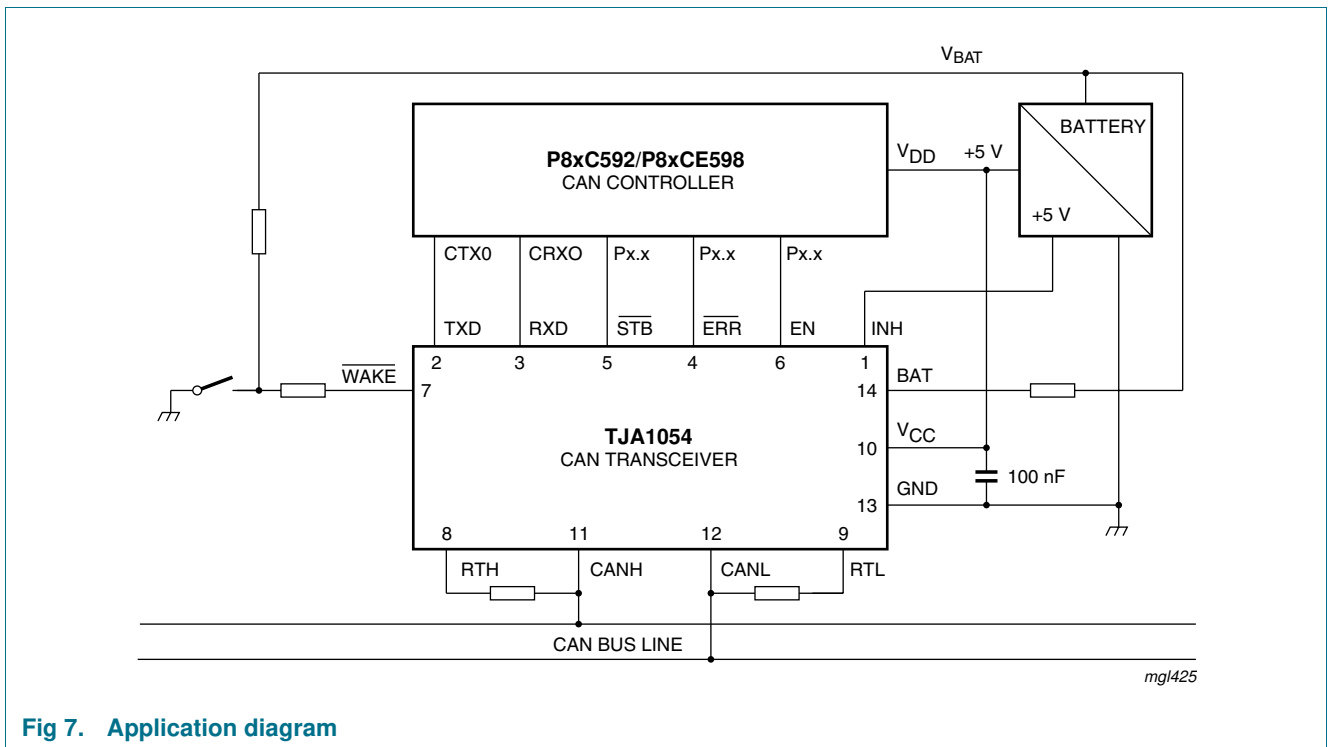
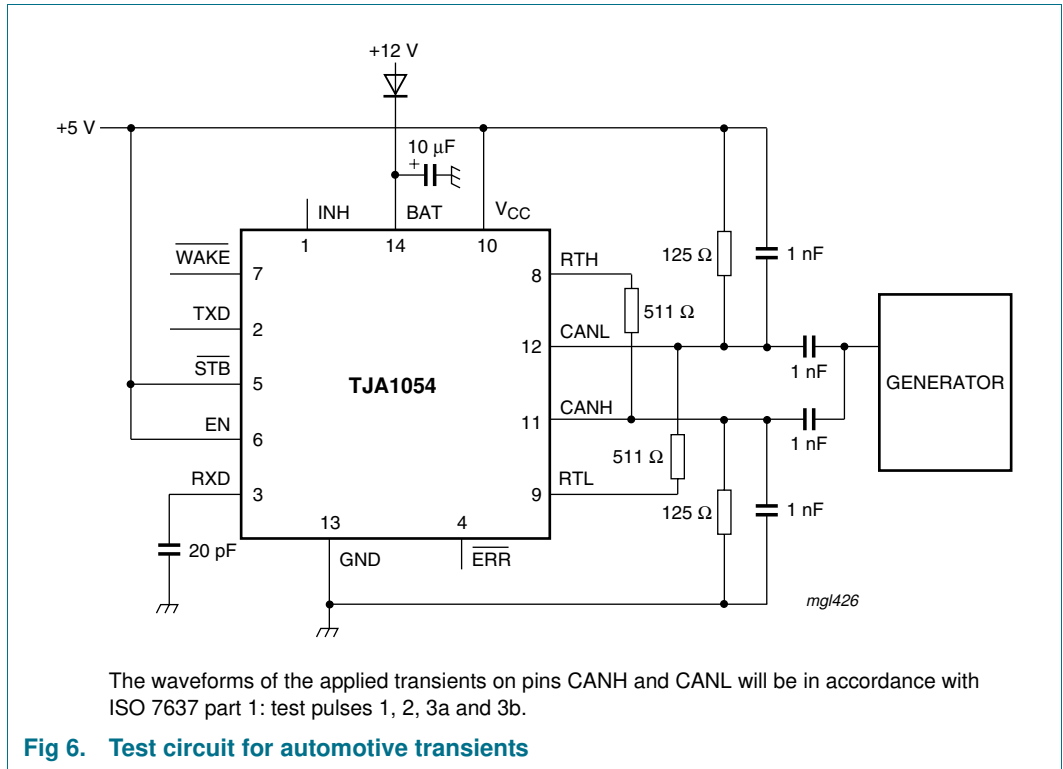

12.1 Quality information

This product has been qualified to the appropriate Automotive Electronics Council (AEC) standard Q100 or Q101 and is suitable for use in automotive applications.

13. Bare die information

Table 10. Bonding pad locations

Symbol	Pad	Coordinates ^[1]	
		x	y
INH	1	106	317
TXD	2	111	169
RXD	3	750	111
$\overline{\text{ERR}}$	4	1347	111
$\overline{\text{STB}}$	5	2248	103
EN	6	2521	240
$\overline{\text{WAKE}}$	7	2521	381
RTH	8	2550	1269
RTL	9	2359	1840
V _{CC}	10	1886	1809
CANH	11	872	1840
CANL	12	437	1840
GND	13a	80	1356
GND	13b	80	1241
BAT	14	106	772

[1] All coordinates (μm) represent the position of the center of each pad with respect to the bottom left-hand corner of the top aluminium layer (see [Figure 8](#)).

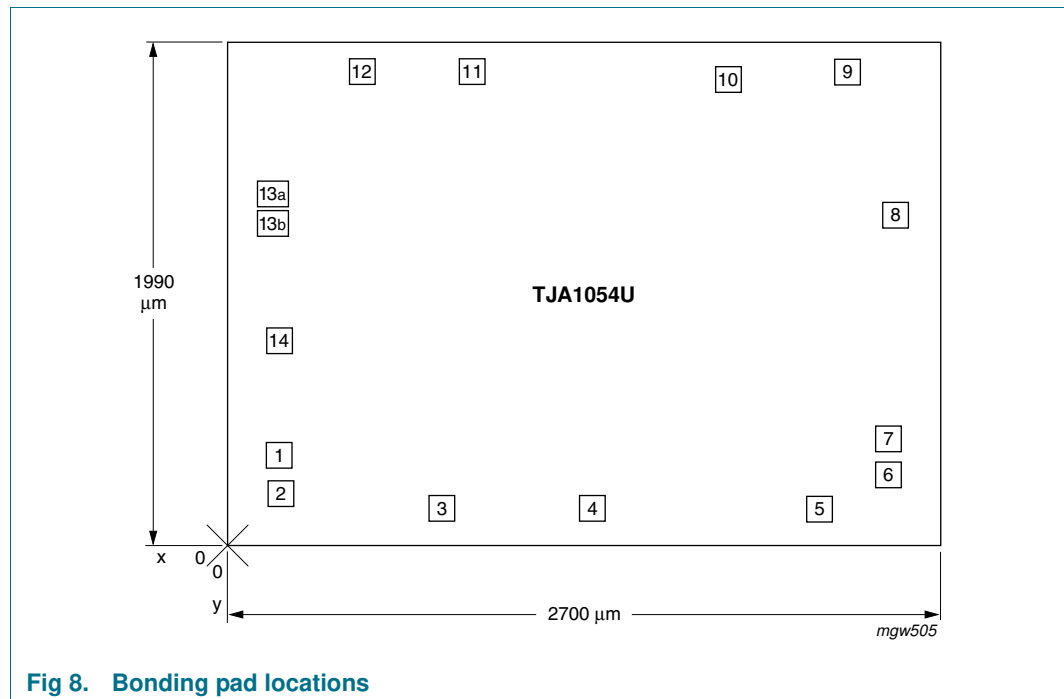

Fig 8. Bonding pad locations

14. Package outline

SO14: plastic small outline package; 14 leads; body width 3.9 mm

SOT108-1

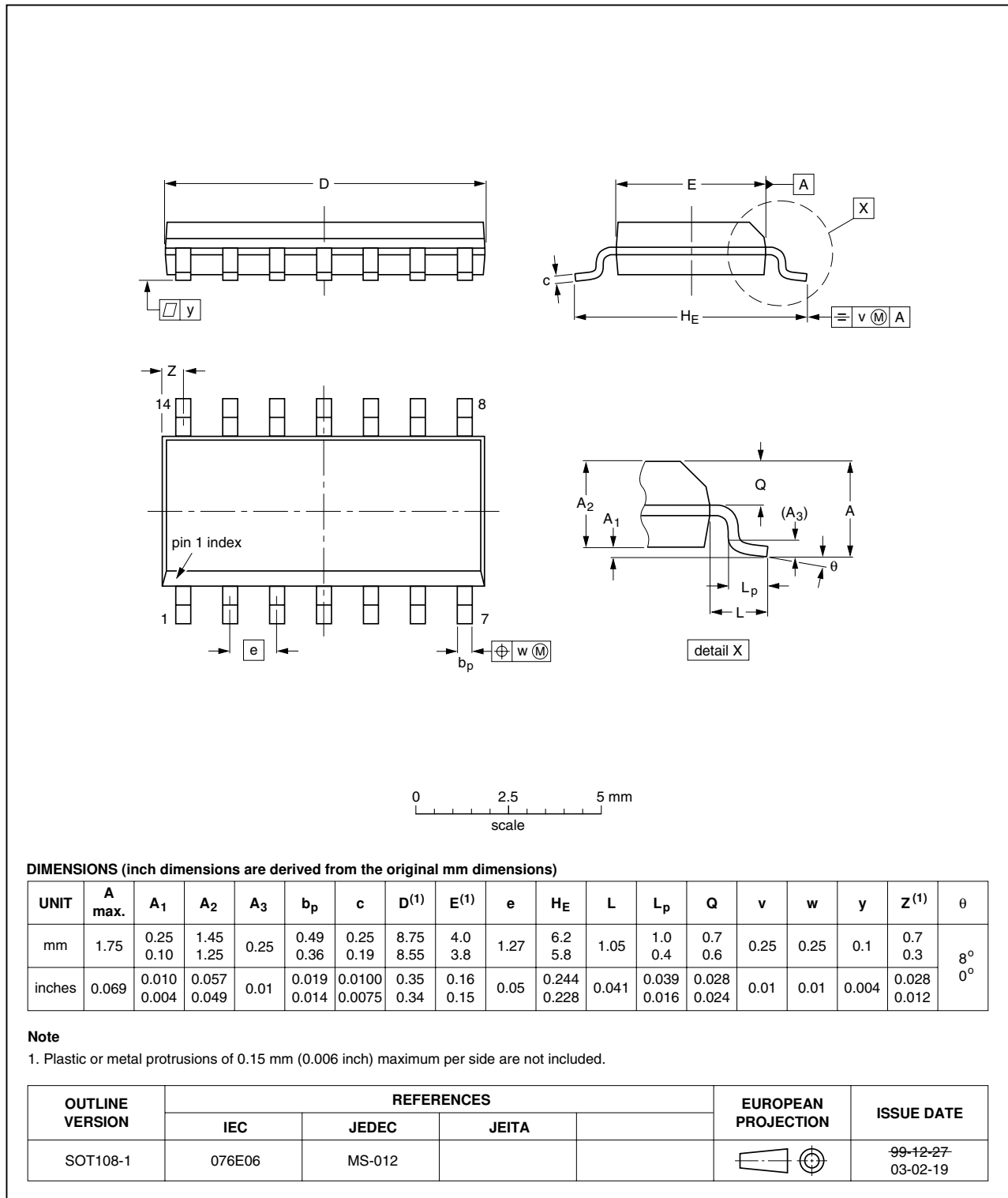

Fig 9. Package outline SOT108-1 (SO14)

15. Soldering of SMD packages

This text provides a very brief insight into a complex technology. A more in-depth account of soldering ICs can be found in Application Note *AN10365 "Surface mount reflow soldering description"*.

15.1 Introduction to soldering

Soldering is one of the most common methods through which packages are attached to Printed Circuit Boards (PCBs), to form electrical circuits. The soldered joint provides both the mechanical and the electrical connection. There is no single soldering method that is ideal for all IC packages. Wave soldering is often preferred when through-hole and Surface Mount Devices (SMDs) are mixed on one printed wiring board; however, it is not suitable for fine pitch SMDs. Reflow soldering is ideal for the small pitches and high densities that come with increased miniaturization.

15.2 Wave and reflow soldering

Wave soldering is a joining technology in which the joints are made by solder coming from a standing wave of liquid solder. The wave soldering process is suitable for the following:

- Through-hole components
- Leaded or leadless SMDs, which are glued to the surface of the printed circuit board

Not all SMDs can be wave soldered. Packages with solder balls, and some leadless packages which have solder lands underneath the body, cannot be wave soldered. Also, leaded SMDs with leads having a pitch smaller than ~0.6 mm cannot be wave soldered, due to an increased probability of bridging.

The reflow soldering process involves applying solder paste to a board, followed by component placement and exposure to a temperature profile. Leaded packages, packages with solder balls, and leadless packages are all reflow solderable.

Key characteristics in both wave and reflow soldering are:

- Board specifications, including the board finish, solder masks and vias
- Package footprints, including solder thieves and orientation
- The moisture sensitivity level of the packages
- Package placement
- Inspection and repair
- Lead-free soldering versus SnPb soldering

15.3 Wave soldering

Key characteristics in wave soldering are:

- Process issues, such as application of adhesive and flux, clinching of leads, board transport, the solder wave parameters, and the time during which components are exposed to the wave
- Solder bath specifications, including temperature and impurities

15.4 Reflow soldering

Key characteristics in reflow soldering are:

- Lead-free versus SnPb soldering; note that a lead-free reflow process usually leads to higher minimum peak temperatures (see [Figure 10](#)) than a SnPb process, thus reducing the process window
- Solder paste printing issues including smearing, release, and adjusting the process window for a mix of large and small components on one board
- Reflow temperature profile; this profile includes preheat, reflow (in which the board is heated to the peak temperature) and cooling down. It is imperative that the peak temperature is high enough for the solder to make reliable solder joints (a solder paste characteristic). In addition, the peak temperature must be low enough that the packages and/or boards are not damaged. The peak temperature of the package depends on package thickness and volume and is classified in accordance with [Table 11](#) and [12](#)

Table 11. SnPb eutectic process (from J-STD-020C)

Package thickness (mm)	Package reflow temperature (°C)	
	Volume (mm ³)	
	< 350	≥ 350
< 2.5	235	220
≥ 2.5	220	220

Table 12. Lead-free process (from J-STD-020C)

Package thickness (mm)	Package reflow temperature (°C)		
	Volume (mm ³)		
	< 350	350 to 2000	> 2000
< 1.6	260	260	260
1.6 to 2.5	260	250	245
> 2.5	250	245	245

Moisture sensitivity precautions, as indicated on the packing, must be respected at all times.

Studies have shown that small packages reach higher temperatures during reflow soldering, see [Figure 10](#).

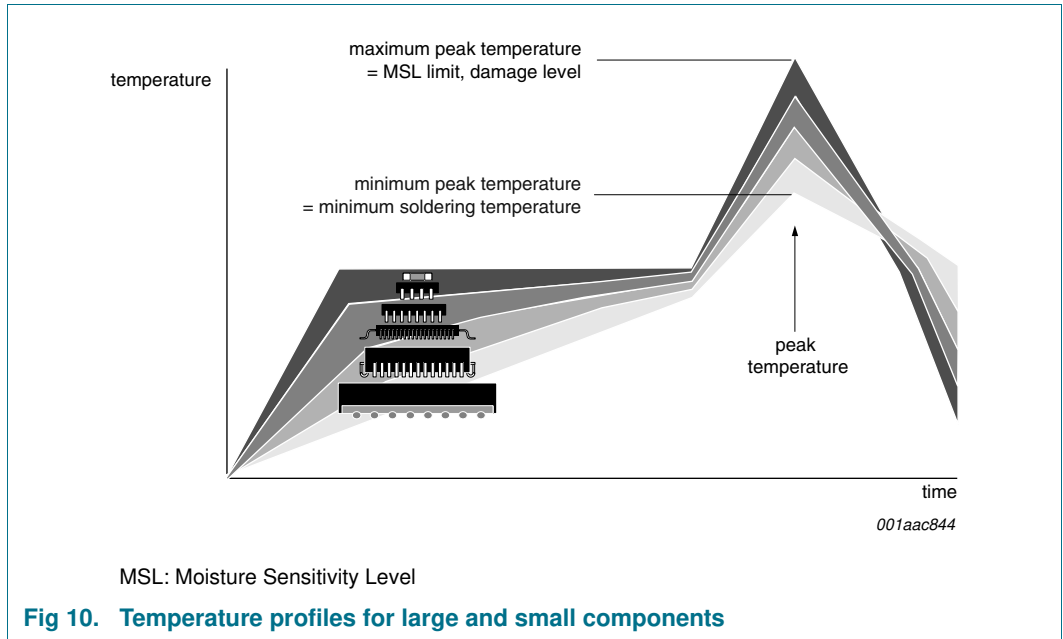

Fig 10. Temperature profiles for large and small components

For further information on temperature profiles, refer to Application Note AN10365 “Surface mount reflow soldering description”.

16. Revision history

Table 13. Revision history

Document ID	Release date	Data sheet status	Change notice	Supersedes
TJA1054 v.4	20100803	Product data sheet	-	TJA1054_3
Modifications:		<ul style="list-style-type: none"> The format of this data sheet has been redesigned to comply with the new identity guidelines of NXP Semiconductors. Legal texts have been adapted to the new company name where appropriate. Value of parameter V_{ESD} (machine model) changed in Table 6. Typing error corrected in Table 8 in the conditions column for I_{BAT}. 		
TJA1054_3 (9397 750 11721)	20040323	Product specification	-	TJA1054_2
TJA1054_2 (9397 750 08965)	20011120	Product specification	-	TJA1054_1
TJA1054_1 (9397 750 03636)	19990211	Preliminary specification	-	-

17. Legal information

17.1 Data sheet status

Document status ^{[1][2]}	Product status ^[3]	Definition
Objective [short] data sheet	Development	This document contains data from the objective specification for product development.
Preliminary [short] data sheet	Qualification	This document contains data from the preliminary specification.
Product [short] data sheet	Production	This document contains the product specification.

[1] Please consult the most recently issued document before initiating or completing a design.

[2] The term 'short data sheet' is explained in section "Definitions".

[3] The product status of device(s) described in this document may have changed since this document was published and may differ in case of multiple devices. The latest product status information is available on the Internet at URL <http://www.nxp.com>.

17.2 Definitions

Draft — The document is a draft version only. The content is still under internal review and subject to formal approval, which may result in modifications or additions. NXP Semiconductors does not give any representations or warranties as to the accuracy or completeness of information included herein and shall have no liability for the consequences of use of such information.

Short data sheet — A short data sheet is an extract from a full data sheet with the same product type number(s) and title. A short data sheet is intended for quick reference only and should not be relied upon to contain detailed and full information. For detailed and full information see the relevant full data sheet, which is available on request via the local NXP Semiconductors sales office. In case of any inconsistency or conflict with the short data sheet, the full data sheet shall prevail.

Product specification — The information and data provided in a Product data sheet shall define the specification of the product as agreed between NXP Semiconductors and its customer, unless NXP Semiconductors and customer have explicitly agreed otherwise in writing. In no event however, shall an agreement be valid in which the NXP Semiconductors product is deemed to offer functions and qualities beyond those described in the Product data sheet.

17.3 Disclaimers

Limited warranty and liability — Information in this document is believed to be accurate and reliable. However, NXP Semiconductors does not give any representations or warranties, expressed or implied, as to the accuracy or completeness of such information and shall have no liability for the consequences of use of such information.

In no event shall NXP Semiconductors be liable for any indirect, incidental, punitive, special or consequential damages (including - without limitation - lost profits, lost savings, business interruption, costs related to the removal or replacement of any products or rework charges) whether or not such damages are based on tort (including negligence), warranty, breach of contract or any other legal theory.

Notwithstanding any damages that customer might incur for any reason whatsoever, NXP Semiconductors' aggregate and cumulative liability towards customer for the products described herein shall be limited in accordance with the *Terms and conditions of commercial sale* of NXP Semiconductors.

Right to make changes — NXP Semiconductors reserves the right to make changes to information published in this document, including without limitation specifications and product descriptions, at any time and without notice. This document supersedes and replaces all information supplied prior to the publication hereof.

Suitability for use — NXP Semiconductors products are not designed, authorized or warranted to be suitable for use in life support, life-critical or safety-critical systems or equipment, nor in applications where failure or

malfunction of an NXP Semiconductors product can reasonably be expected to result in personal injury, death or severe property or environmental damage. NXP Semiconductors accepts no liability for inclusion and/or use of NXP Semiconductors products in such equipment or applications and therefore such inclusion and/or use is at the customer's own risk.

Applications — Applications that are described herein for any of these products are for illustrative purposes only. NXP Semiconductors makes no representation or warranty that such applications will be suitable for the specified use without further testing or modification.

Customers are responsible for the design and operation of their applications and products using NXP Semiconductors products, and NXP Semiconductors accepts no liability for any assistance with applications or customer product design. It is customer's sole responsibility to determine whether the NXP Semiconductors product is suitable and fit for the customer's applications and products planned, as well as for the planned application and use of customer's third party customer(s). Customers should provide appropriate design and operating safeguards to minimize the risks associated with their applications and products.

NXP Semiconductors does not accept any liability related to any default, damage, costs or problem which is based on any weakness or default in the customer's applications or products, or the application or use by customer's third party customer(s). Customer is responsible for doing all necessary testing for the customer's applications and products using NXP Semiconductors products in order to avoid a default of the applications and the products or of the application or use by customer's third party customer(s). NXP does not accept any liability in this respect.

Limiting values — Stress above one or more limiting values (as defined in the Absolute Maximum Ratings System of IEC 60134) will cause permanent damage to the device. Limiting values are stress ratings only and (proper) operation of the device at these or any other conditions above those given in the Recommended operating conditions section (if present) or the Characteristics sections of this document is not warranted. Constant or repeated exposure to limiting values will permanently and irreversibly affect the quality and reliability of the device.

Terms and conditions of commercial sale — NXP Semiconductors products are sold subject to the general terms and conditions of commercial sale, as published at <http://www.nxp.com/profile/terms>, unless otherwise agreed in a valid written individual agreement. In case an individual agreement is concluded only the terms and conditions of the respective agreement shall apply. NXP Semiconductors hereby expressly objects to applying the customer's general terms and conditions with regard to the purchase of NXP Semiconductors products by customer.

No offer to sell or license — Nothing in this document may be interpreted or construed as an offer to sell products that is open for acceptance or the grant, conveyance or implication of any license under any copyrights, patents or other industrial or intellectual property rights.

Export control — This document as well as the item(s) described herein may be subject to export control regulations. Export might require a prior authorization from national authorities.

Bare die — All die are tested on compliance with their related technical specifications as stated in this data sheet up to the point of wafer sawing and are handled in accordance with the NXP Semiconductors storage and transportation conditions. If there are data sheet limits not guaranteed, these will be separately indicated in the data sheet. There are no post-packing tests performed on individual die or wafers.

NXP Semiconductors has no control of third party procedures in the sawing, handling, packing or assembly of the die. Accordingly, NXP Semiconductors assumes no liability for device functionality or performance of the die or systems after third party sawing, handling, packing or assembly of the die. It is the responsibility of the customer to test and qualify their application in which the die is used.

All die sales are conditioned upon and subject to the customer entering into a written die sale agreement with NXP Semiconductors through its legal department.

Quick reference data — The Quick reference data is an extract of the product data given in the Limiting values and Characteristics sections of this document, and as such is not complete, exhaustive or legally binding.

17.4 Trademarks

Notice: All referenced brands, product names, service names and trademarks are the property of their respective owners.

18. Contact information

For more information, please visit: <http://www.nxp.com>

For sales office addresses, please send an email to: salesaddresses@nxp.com

19. Contents

1	General description	1
2	Features and benefits	1
2.1	Optimized for in-car low-speed communication	1
2.2	Bus failure management	1
2.3	Protections	2
2.4	Support for low power modes	2
3	Quick reference data	2
4	Ordering information	3
5	Block diagram	3
6	Pinning information	4
6.1	Pinning	4
6.2	Pin description	4
7	Functional description	5
7.1	Failure detector	5
7.2	Low power modes	7
7.3	Power-on	8
7.4	Protections	8
8	Limiting values	9
9	Thermal characteristics	10
10	Static characteristics	11
11	Dynamic characteristics	14
12	Test information	16
12.1	Quality information	17
13	Bare die information	18
14	Package outline	19
15	Soldering of SMD packages	20
15.1	Introduction to soldering	20
15.2	Wave and reflow soldering	20
15.3	Wave soldering	20
15.4	Reflow soldering	21
16	Revision history	22
17	Legal information	23
17.1	Data sheet status	23
17.2	Definitions	23
17.3	Disclaimers	23
17.4	Trademarks	24
18	Contact information	24
19	Contents	25

Please be aware that important notices concerning this document and the product(s) described herein, have been included in section 'Legal information'.

© NXP B.V. 2010.

All rights reserved.

For more information, please visit: <http://www.nxp.com>

For sales office addresses, please send an email to: salesaddresses@nxp.com

Date of release: 3 August 2010

Document identifier: TJA1054