



## VN5E010AH

### 10 mΩ high-side driver with analog current sense for automotive applications

#### Features

Max supply voltage	$V_{CC}$	41 V
Operating voltage range	$V_{CC}$	4.5 V to 28 V
Typ. ON-state resistance	$R_{ON}$	10 mΩ
Current limitation (typ)	$I_{LIMH}$	85 A
OFF-state supply current	$I_S$	2 μA <sup>(1)</sup>

1. Typical value with all loads connected

- General
  - Inrush current active management by power limitation
  - Very low standby current
  - 3 V CMOS compatible inputs
  - Optimized electromagnetic emissions
  - Very low electromagnetic susceptibility
  - In compliance with the 2002/95/EC european directive
  - Very low current sense leakage
- Diagnostic functions
  - Proportional load current sense
  - High current sense precision for wide current range
  - Current sense disable
  - OFF-state open-load detection
  - Output short to  $V_{CC}$  detection
  - Overload and short to ground (power limitation) indication
  - Thermal shutdown indication
- Protection
  - Undervoltage shutdown
  - Overvoltage clamp
  - Load current limitation
  - Self limiting of fast thermal transients
  - Protection against loss of ground and loss of  $V_{CC}$
  - Overtemperature shut down with autorestart (thermal shutdown)



- Reverse battery protection with self switch on of the Power MOSFET (see [Figure 32](#))
- Electrostatic discharge protection

#### Applications

- All types of resistive, inductive and capacitive loads
- Suitable as LED driver

#### Description

The VN5E010AH is a single-channel high-side driver manufactured in the ST proprietary VIPower M0-5 technology and housed in the tiny HPAK package. The VN5E010AH is designed to drive 12 V automotive grounded loads delivering protection, diagnostics and easy 3 V and 5 V CMOS compatible interface with any microcontroller.

The device integrates advanced protective functions such as load current limitation, inrush and overload active management by power limitation, overtemperature shut-off with auto-restart and overvoltage active clamp. A dedicated analog current sense pin is associated with every output channel in order to provide enhanced diagnostic functions including fast detection of overload and short-circuit to ground through power limitation indication, overtemperature indication, short-circuit to  $V_{CC}$  diagnosis and ON- and OFF-state open-load detection.

The current sensing and diagnostic feedback of the whole device can be disabled by pulling the CS\_DIS pin high to allow sharing of the external sense resistor with other similar devices.

# Contents

<b>1</b>	<b>Block diagram and pin configuration</b>	<b>5</b>
<b>2</b>	<b>Electrical specifications</b>	<b>7</b>
2.1	Absolute maximum ratings	7
2.2	Thermal data	8
2.3	Electrical characteristics	9
2.4	Waveforms	18
2.5	Electrical characteristics curves	21
<b>3</b>	<b>Application information</b>	<b>24</b>
3.1	Load dump protection	24
3.2	MCU I/Os protection	24
3.3	Current sense and diagnostic	25
3.3.1	Short to VCC and OFF-state open-load detection	26
3.4	Maximum demagnetization energy (VCC = 13.5 V)	27
<b>4</b>	<b>Package and PC board thermal data</b>	<b>28</b>
4.1	HPAK thermal data	28
<b>5</b>	<b>Package and packing information</b>	<b>31</b>
5.1	ECOPACK®	31
5.2	HPAK mechanical data	31
5.3	HPAK suggested land pattern	33
5.4	Packing information	34
<b>6</b>	<b>Order codes</b>	<b>35</b>
<b>7</b>	<b>Revision history</b>	<b>36</b>

## List of tables

Table 1.	Pin functions . . . . .	5
Table 2.	Suggested connections for unused and not connected pins . . . . .	6
Table 3.	Absolute maximum ratings . . . . .	7
Table 4.	Thermal data . . . . .	8
Table 5.	Power section . . . . .	9
Table 6.	Switching ( $V_{CC} = 13\text{ V}$ , $T_j = 25\text{ }^\circ\text{C}$ ) . . . . .	9
Table 7.	Logic inputs . . . . .	10
Table 8.	Protection and diagnostics . . . . .	10
Table 9.	Current sense ( $8\text{ V} < V_{CC} < 18\text{ V}$ ) . . . . .	11
Table 10.	Open load detection ( $8\text{ V} < V_{CC} < 18\text{ V}$ ) . . . . .	12
Table 11.	Truth table . . . . .	16
Table 12.	Electrical transient requirements (part 1) . . . . .	17
Table 13.	Electrical transient requirements (part 2) . . . . .	17
Table 14.	Electrical transient requirements (part 3) . . . . .	17
Table 15.	Thermal parameter . . . . .	30
Table 16.	HPAK mechanical data . . . . .	32
Table 17.	Device summary . . . . .	35
Table 18.	Document revision history . . . . .	36

## List of figures

Figure 1.	Block diagram . . . . .	5
Figure 2.	Configuration diagram (top view) not in scale. . . . .	6
Figure 3.	Current and voltage conventions . . . . .	7
Figure 4.	Current sense delay characteristics . . . . .	13
Figure 5.	Open-load OFF-state delay timing . . . . .	13
Figure 6.	Switching characteristics . . . . .	13
Figure 7.	Delay response time between rising edge of output current and rising edge of current sense (CS enabled). . . . .	14
Figure 8.	Output voltage drop limitation . . . . .	14
Figure 9.	$I_{OUT}/I_{SENSE}$ vs. $I_{OUT}$ . . . . .	15
Figure 10.	Maximum current sense ratio drift vs. load current <sup>(1)</sup> . . . . .	15
Figure 11.	Normal operation . . . . .	18
Figure 12.	Overload or short to GND . . . . .	18
Figure 13.	Intermittent overload . . . . .	19
Figure 14.	OFF-state open-load with external circuitry . . . . .	19
Figure 15.	Short to $V_{CC}$ . . . . .	20
Figure 16.	$T_J$ evolution in overload or short to GND . . . . .	20
Figure 17.	OFF-state output current . . . . .	21
Figure 18.	High-level input current . . . . .	21
Figure 19.	Input clamp voltage . . . . .	21
Figure 20.	Low-level input voltage . . . . .	21
Figure 21.	High-level input voltage . . . . .	21
Figure 22.	Input hysteresis voltage . . . . .	21
Figure 23.	ON-state resistance vs. $T_{case}$ . . . . .	22
Figure 24.	ON-state resistance vs. $V_{CC}$ . . . . .	22
Figure 25.	Undervoltage shutdown . . . . .	22
Figure 26.	Turn-on voltage slope . . . . .	22
Figure 27.	$I_{LIMH}$ Vs. $T_{case}$ . . . . .	22
Figure 28.	Turn-off voltage slope . . . . .	22
Figure 29.	High-level $CS\_DIS$ voltage . . . . .	23
Figure 30.	$CS\_DIS$ clamp voltage . . . . .	23
Figure 31.	Low-level $CS\_DIS$ voltage . . . . .	23
Figure 32.	Application schematic . . . . .	24
Figure 33.	Current sense and diagnostic . . . . .	25
Figure 34.	Maximum turn-off current versus inductance <sup>(1)</sup> . . . . .	27
Figure 35.	PC board <sup>(1)</sup> . . . . .	28
Figure 36.	$R_{thj-amb}$ vs. PCB copper area in open box free air condition . . . . .	28
Figure 37.	HPAK thermal impedance junction ambient single pulse . . . . .	29
Figure 38.	Thermal fitting model of a single-channel HSD in HPAK <sup>(1)</sup> . . . . .	29
Figure 39.	HPAK package dimension . . . . .	31
Figure 40.	<b>HPAK</b> suggested pad layout <sup>(1)</sup> . . . . .	33
Figure 41.	<b>HPAK</b> tube shipment (no suffix) . . . . .	34
Figure 42.	<b>HPAK</b> tape and reel (suffix "TR") . . . . .	34

# 1 Block diagram and pin configuration

Figure 1. Block diagram

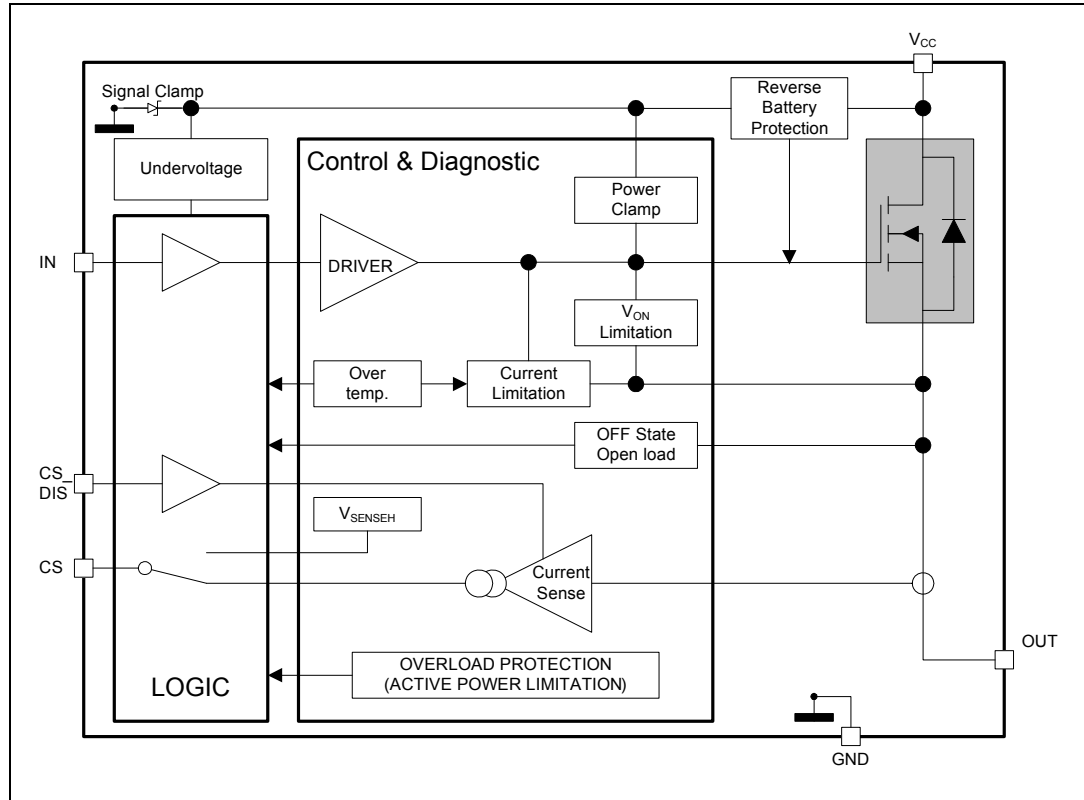

Table 1. Pin functions

Name	Function
V <sub>CC</sub>	Battery connection
OUT	Power output <sup>(1)</sup>
GND	Ground connection
IN	Voltage controlled input pin with hysteresis, CMOS compatible. Controls output switch state
CS	Analog CS pin, delivers a current proportional to the load current
CS_DIS	Active high CMOS compatible pin, to disable the CS pin

1. Pins 1 and 7 must be externally tied together.

Figure 2. Configuration diagram (top view) not in scale

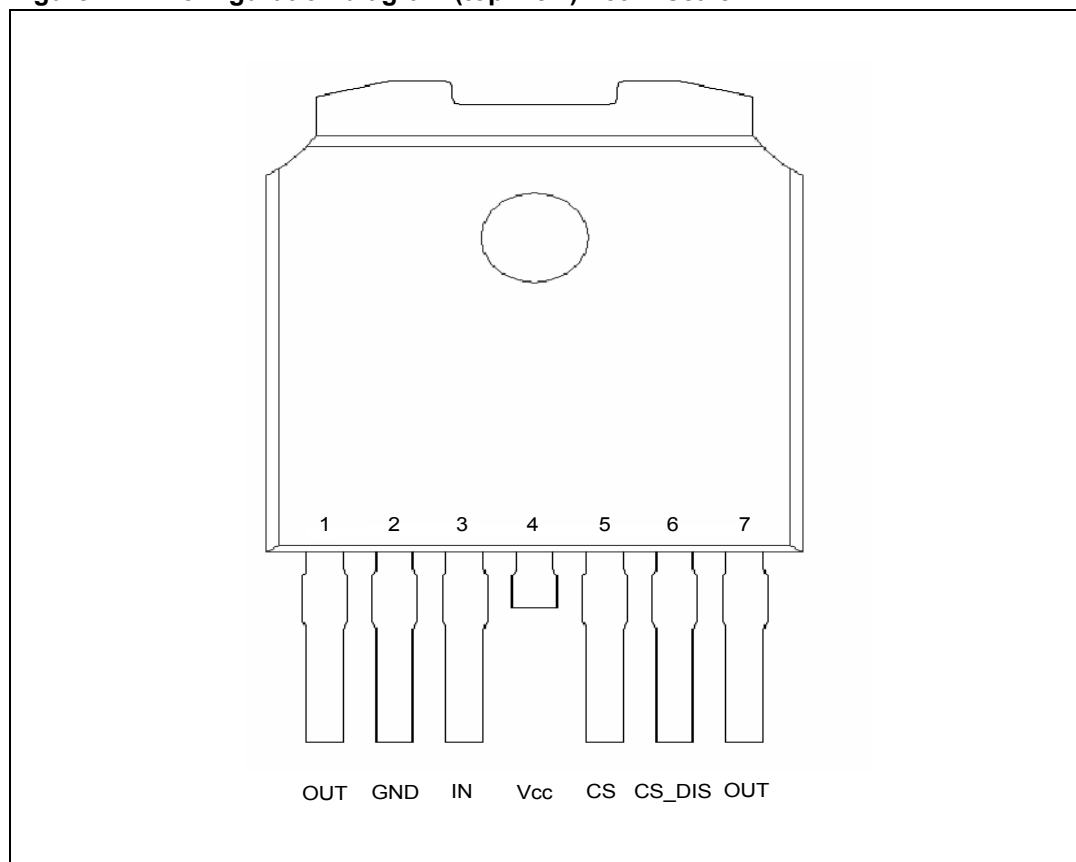
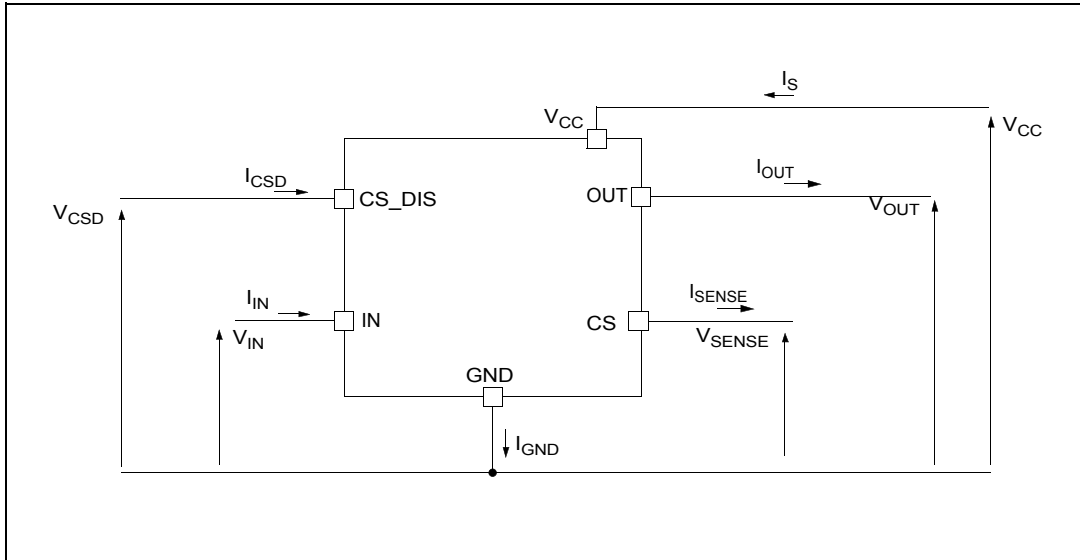

Table 2. Suggested connections for unused and not connected pins

Connection / pin	CS	OUT	IN	CS_DIS
Floating	Not allowed	X	X	X
To ground	Through 1 kΩ resistor	Through 22 kΩ resistor	Through 10 kΩ resistor	Through 10 kΩ resistor

## 2 Electrical specifications

Figure 3. Current and voltage conventions



### 2.1 Absolute maximum ratings

Stressing the device above the rating listed in the [Table 3: Absolute maximum ratings](#) may cause permanent damage to the device. These are stress ratings only and operation of the device at these or any other conditions above those indicated in the operating sections of this specification is not implied. Exposure to absolute maximum rating conditions for extended periods may affect device reliability. Refer also to the STMicroelectronics SURE program and other relevant quality document.

Table 3. Absolute maximum ratings

Symbol	Parameter	Value	Unit
$V_{CC}$	DC supply voltage	41	V
$-V_{CC}$	Reverse DC supply voltage	16	V
$I_{OUT}$	DC output current	Internally limited	A
$-I_{OUT}$	Reverse DC output current	20	A
$I_{IN}$	DC input current	-1 to 10	mA
$I_{CS_D}$	DC current sense disable input current	-1 to 10	mA
$V_{CS_{SENSE}}$	Current sense maximum voltage ( $V_{CC} > 0$ )	$V_{CC} - 41$ $+V_{CC}$	V V
$E_{MAX}$	Maximum switching energy (single pulse) ( $L = 2.2 \text{ mH}$ ; $R_L = 0 \text{ }\Omega$ ; $V_{BAT} = 13.5 \text{ V}$ ; $T_{jstart} = 150 \text{ }^\circ\text{C}$ ; $I_{OUT} = I_{limL}(Typ.)$ )	645	mJ

**Table 3. Absolute maximum ratings (continued)**

Symbol	Parameter	Value	Unit
V <sub>ESD</sub>	Electrostatic discharge (human body model: R = 1.5 kΩ; C = 100 pF)		
	– IN	4000	V
	– CS	2000	V
	– CS_DIS	4000	V
	– OUT	5000	V
	– V <sub>CC</sub>	5000	V
V <sub>ESD</sub>	Charge device model (CDM-AEC-Q100-011)	750	V
T <sub>j</sub>	Junction operating temperature	-40 to 150	°C
T <sub>stg</sub>	Storage temperature	-55 to 150	°C

## 2.2 Thermal data

**Table 4. Thermal data**

Symbol	Parameter	Max. value	Unit
R <sub>thj-case</sub>	Thermal resistance junction-case	0.55	°C/W
R <sub>thj-amb</sub>	Thermal resistance junction-ambient	67.7	°C/W



## 2.3 Electrical characteristics

Values specified in this section are for  $8\text{ V} < V_{CC} < 28\text{ V}$ ,  $-40\text{ °C} < T_j < 150\text{ °C}$ , unless otherwise specified.

**Table 5. Power section**

Symbol	Parameter	Test conditions	Min.	Typ.	Max.	Unit
$V_{CC}$	Operating supply voltage		4.5	13	28	V
$V_{USD}$	Undervoltage shutdown			3.5	4.5	V
$V_{USDhyst}$	Undervoltage shutdown hysteresis			0.5		V
$R_{ON}$	ON-state resistance	$I_{OUT} = 6\text{ A}$ ; $T_j = 25\text{ °C}$		10		m $\Omega$
		$I_{OUT} = 6\text{ A}$ ; $T_j = 150\text{ °C}$			20	
		$I_{OUT} = 6\text{ A}$ ; $V_{CC} = 5\text{ V}$ ; $T_j = 25\text{ °C}$			13	
$R_{ON-Rev}$	$R_{DS(on)}$ in reverse battery condition	$V_{CC} = -13\text{ V}$ ; $I_{OUT} = -6\text{ A}$ ; $T_j = 25\text{ °C}$		10		m $\Omega$
$V_{clamp}$	Clamp voltage	$I_{CC} = 20\text{ mA}$ ; $I_{OUT} = 0\text{ A}$	41	46	52	V
$I_S$	Supply current	OFF-state: $V_{CC} = 13\text{ V}$ ; $T_j = 25\text{ °C}$ ; $V_{IN} = V_{OUT} = V_{SENSE} = 0\text{ V}$		2	5	$\mu\text{A}$
		ON-state: $V_{CC} = 13\text{ V}$ ; $V_{IN} = 5\text{ V}$ ; $I_{OUT} = 0\text{ A}$		1.5	3	mA
$I_{L(off)}$	OFF-state output current	$V_{IN} = V_{OUT} = 0\text{ V}$ ; $V_{CC} = 13\text{ V}$ ; $T_j = 25\text{ °C}$	0	0.01	3	$\mu\text{A}$
		$V_{IN} = V_{OUT} = 0\text{ V}$ ; $V_{CC} = 13\text{ V}$ ; $T_j = 125\text{ °C}$	0		5	

**Table 6. Switching ( $V_{CC} = 13\text{ V}$ ,  $T_j = 25\text{ °C}$ )**

Symbol	Parameter	Test conditions	Min.	Typ.	Max.	Unit
$t_{d(on)}$	Turn-on delay time	$R_L = 2.2\ \Omega$ (see <a href="#">Figure 6</a> )	-	40	-	$\mu\text{s}$
$t_{d(off)}$	Turn-off delay time	$R_L = 2.2\ \Omega$ (see <a href="#">Figure 6</a> )	-	28	-	$\mu\text{s}$
$(dV_{OUT}/dt)_{on}$	Turn-on voltage slope	$R_L = 2.2\ \Omega$	-	(see <a href="#">Figure 26</a> )	-	V/ $\mu\text{s}$
$(dV_{OUT}/dt)_{off}$	Turn-off voltage slope	$R_L = 2.2\ \Omega$	-	(see <a href="#">Figure 28</a> )	-	V/ $\mu\text{s}$
$W_{ON}$	Switching energy losses at turn-on ( $t_{won}$ )	$R_L = 2.2\ \Omega$ (see <a href="#">Figure 6</a> )	-	2	-	mJ
$W_{OFF}$	Switching energy losses at turn-off ( $t_{woff}$ )	$R_L = 2.2\ \Omega$ (see <a href="#">Figure 6</a> )	-	0.6	-	mJ

**Table 7. Logic inputs**

Symbol	Parameter	Test conditions	Min.	Typ.	Max.	Unit
$V_{IL}$	Low-level input voltage				0.9	V
$I_{IL}$	Low-level input current	$V_{IN} = 0.9\text{ V}$	1			$\mu\text{A}$
$V_{IH}$	High-level input voltage		2.1			V
$I_{IH}$	High-level input current	$V_{IN} = 2.1\text{ V}$			10	$\mu\text{A}$
$V_{I(hyst)}$	Input hysteresis voltage		0.25			V
$V_{ICL}$	Input clamp voltage	$I_{IN} = 1\text{ mA}$	5.5		7	V
		$I_{IN} = -1\text{ mA}$		-0.7		
$V_{CSDL}$	Low-level CS_DIS voltage				0.9	V
$I_{CSDL}$	Low-level CS_DIS current	$V_{CSD} = 0.9\text{ V}$	1			$\mu\text{A}$
$V_{CSDH}$	High-level CS_DIS voltage		2.1			V
$I_{CSDH}$	High-level CS_DIS current	$V_{CSD} = 2.1\text{ V}$			10	$\mu\text{A}$
$V_{CSD(hyst)}$	CS_DIS hysteresis voltage		0.25			V
$V_{CSCL}$	CS_DIS clamp voltage	$I_{CSD} = 1\text{ mA}$	5.5		7	V
		$I_{CSD} = -1\text{ mA}$		-0.7		

**Table 8. Protection and diagnostics<sup>(1)</sup>**

Symbol	Parameter	Test conditions	Min.	Typ.	Max.	Unit
$I_{limH}$	Short-circuit current	$V_{CC} = 13\text{ V}$	60	85	120	A
		$5\text{ V} < V_{CC} < 28\text{ V}$			120	
$I_{limL}$	Short-circuit current during thermal cycling	$V_{CC} = 13\text{ V};$ $T_R < T_j < T_{TSD}$		21		A
$T_{TSD}$	Shutdown temperature		150	175	200	$^{\circ}\text{C}$
$T_R$	Reset temperature		$T_{RS} + 1$	$T_{RS} + 5$		$^{\circ}\text{C}$
$T_{RS}$	Thermal reset of status		135			$^{\circ}\text{C}$
$T_{HYST}$	Thermal hysteresis ( $T_{TSD} - T_R$ )			7		$^{\circ}\text{C}$
$V_{DEMAG}$	Turn-off output voltage clamp	$I_{OUT} = 2\text{ A}; V_{IN} = 0;$ $L = 6\text{ mH}$	$V_{CC} - 41$	$V_{CC} - 46$	$V_{CC} - 52$	V
$V_{ON}$	Output voltage drop limitation	$I_{OUT} = 0.5\text{ A};$ $T_j = -40\text{ }^{\circ}\text{C} \text{ to } 150\text{ }^{\circ}\text{C}$		25		mV

1. To ensure long term reliability under heavy overload or short-circuit conditions, protection and related diagnostic signals must be used together with a proper software strategy. If the device is subjected to abnormal conditions, this software must limit the duration and number of activation cycles

Table 9. Current sense ( $8\text{ V} < V_{CC} < 18\text{ V}$ )

Symbol	Parameter	Test conditions	Min.	Typ.	Max.	Unit
$K_0$	$I_{OUT}/I_{SENSE}$	$I_{OUT} = 0.25\text{ A}; V_{SENSE} = 0.5\text{ V}$ $T_j = -40\text{ }^\circ\text{C to }150\text{ }^\circ\text{C}$ $T_j = 25\text{ }^\circ\text{C to }150\text{ }^\circ\text{C}$	3000 3000	7410 7410	12000 11600	
$K_1$	$I_{OUT}/I_{SENSE}$	$I_{OUT} = 6\text{ A}; V_{SENSE} = 0.5\text{ V}$ $T_j = -40\text{ }^\circ\text{C to }150\text{ }^\circ\text{C}$ $T_j = 25\text{ }^\circ\text{C to }150\text{ }^\circ\text{C}$	5350 5510	6740 6740	8500 7745	
$dK_1/K_1^{(1)}$	Current sense ratio drift	$I_{OUT} = 6\text{ A}; V_{SENSE} = 0.5\text{ V};$ $V_{CSD}=0\text{V};$ $T_j = -40\text{ }^\circ\text{C to }150\text{ }^\circ\text{C}$	-15		15	%
$K_2$	$I_{OUT}/I_{SENSE}$	$I_{OUT} = 10\text{ A}; V_{SENSE} = 4\text{ V}$ $T_j = -40\text{ }^\circ\text{C to }150\text{ }^\circ\text{C}$ $T_j = 25\text{ }^\circ\text{C to }150\text{ }^\circ\text{C}$	5850 5800	6570 6570	7690 7195	
$dK_2/K_2^{(1)}$	Current sense ratio drift	$I_{OUT} = 10\text{ A}; V_{SENSE}=4\text{ V};$ $V_{CSD} = 0\text{ V};$ $T_j = -40\text{ }^\circ\text{C to }150\text{ }^\circ\text{C}$	-11		11	%
$K_3$	$I_{OUT}/I_{SENSE}$	$I_{OUT} = 25\text{ A}; V_{SENSE} = 4\text{ V}$ $T_j = -40\text{ }^\circ\text{C to }150\text{ }^\circ\text{C}$ $T_j = 25\text{ }^\circ\text{C to }150\text{ }^\circ\text{C}$	5915 5850	6420 6420	7000 6755	
$dK_3/K_3^{(1)}$	Current sense ratio drift	$I_{OUT} = 25\text{ A}; V_{SENSE}=4\text{ V};$ $V_{CSD} = 0\text{ V};$ $T_j = -40\text{ }^\circ\text{C to }150\text{ }^\circ\text{C}$	-8		8	%
$I_{SENSE0}$	Analog sense leakage current	$I_{OUT} = 0\text{ A}; V_{SENSE} = 0\text{ V};$ $V_{CSD} = 5\text{ V}; V_{IN}=0\text{ V};$ $T_j = -40\text{ }^\circ\text{C to }150\text{ }^\circ\text{C}$	0		1	$\mu\text{A}$
		$I_{OUT} = 0\text{ A}; V_{SENSE} = 0\text{ V};$ $V_{CSD} = 0\text{ V}; V_{IN} = 5\text{ V};$ $T_j = -40\text{ }^\circ\text{C to }150\text{ }^\circ\text{C}$	0		2	
		$I_{OUT} = 2\text{ A}; V_{SENSE} = 0\text{ V};$ $V_{CSD} = 5\text{ V}; V_{IN} = 5\text{ V};$ $T_j = -40\text{ }^\circ\text{C to }150\text{ }^\circ\text{C}$			1	
$I_{OL}$	Open load ON-state current detection threshold	$V_{IN} = 5\text{ V}, 8\text{ V} < V_{CC} < 18\text{ V}$ $I_{SENSE} = 5\text{ }\mu\text{A}$	5		80	mA
$V_{SENSE}$	Max analog sense output voltage	$I_{OUT} = 18\text{ A}; R_{SENSE} = 3.9\text{ k}\Omega$	5			V
$V_{SENSEH}^{(2)}$	Analog sense output voltage in fault condition	$V_{CC} = 13\text{ V}; R_{SENSE} = 3.9\text{ k}\Omega$		8		V
$I_{SENSEH}^{(2)}$	Analog sense output current in fault condition	$V_{CC} = 13\text{ V}; V_{SENSE} = 5\text{ V}$		9		mA

**Table 9. Current sense (8 V < V<sub>CC</sub> < 18 V) (continued)**

Symbol	Parameter	Test conditions	Min.	Typ.	Max.	Unit
t <sub>DSENSE1H</sub>	Delay response time from falling edge of CS_DIS pin	V <sub>SENSE</sub> < 4 V, 1.5 A < I <sub>OUT</sub> < 25 A I <sub>SENSE</sub> = 90% of I <sub>SENSE max</sub> (see <a href="#">Figure 4</a> )		50	100	μs
t <sub>DSENSE1L</sub>	Delay response time from rising edge of CS_DIS pin	V <sub>SENSE</sub> < 4 V, 1.5 A < I <sub>OUT</sub> < 25 A I <sub>SENSE</sub> = 10% of I <sub>SENSE max</sub> (see <a href="#">Figure 4</a> )		5	20	μs
t <sub>DSENSE2H</sub>	Delay response time from rising edge of IN pin	V <sub>SENSE</sub> < 4 V, 1.5 A < I <sub>OUT</sub> < 25 A I <sub>SENSE</sub> = 90% of I <sub>SENSE max</sub> (see <a href="#">Figure 4</a> )		270	600	μs
Δt <sub>DSENSE2H</sub>	Delay response time between rising edge of output current and rising edge of current sense	V <sub>SENSE</sub> < 4 V, I <sub>SENSE</sub> = 90% of I <sub>SENSEMAX</sub> , I <sub>OUT</sub> = 90% of I <sub>OUTMAX</sub> I <sub>OUTMAX</sub> = 3 A (see <a href="#">Figure 7</a> )			310	μs
t <sub>DSENSE2L</sub>	Delay response time from falling edge of IN pin	V <sub>SENSE</sub> < 4 V, 1.5 A < I <sub>OUT</sub> < 25 A I <sub>SENSE</sub> = 10% of I <sub>SENSE max</sub> (see <a href="#">Figure 4</a> )		100	250	μs

- Parameter guaranteed by design, it is not tested.
- Fault condition includes: power limitation, over-temperature and open load OFF-state detection.

**Table 10. Open load detection (8 V < V<sub>CC</sub> < 18 V)**

Symbol	Parameter	Test conditions	Min.	Typ.	Max.	Unit
V <sub>OL</sub>	Open-load OFF-state voltage detection threshold	V <sub>IN</sub> = 0 V	2	See <a href="#">Figure 5</a>	4	V
t <sub>DSTKON</sub>	Output short-circuit to V <sub>CC</sub> detection delay at turn-off	See <a href="#">Figure 5</a>	180		1200	μs
I <sub>L(off2)r</sub>	OFF-state output current at V <sub>OUT</sub> = 4 V	V <sub>IN</sub> = 0 V; V <sub>SENSE</sub> = 0 V V <sub>OUT</sub> rising from 0 V to 4 V	-120		90	μA
I <sub>L(off2)f</sub>	OFF-state output current at V <sub>OUT</sub> = 2 V	V <sub>IN</sub> = 0 V; V <sub>SENSE</sub> = V <sub>SENSEH</sub> ; V <sub>OUT</sub> falling from V <sub>CC</sub> to 2 V	-50		90	μA
t <sub>d_vol</sub>	Delay response from output rising edge to V <sub>SENSE</sub> rising edge in open-load	V <sub>OUT</sub> = 4 V; V <sub>IN</sub> = 0 V V <sub>SENSE</sub> = 90% of V <sub>SENSEH</sub>			20	μs

**Figure 4. Current sense delay characteristics**

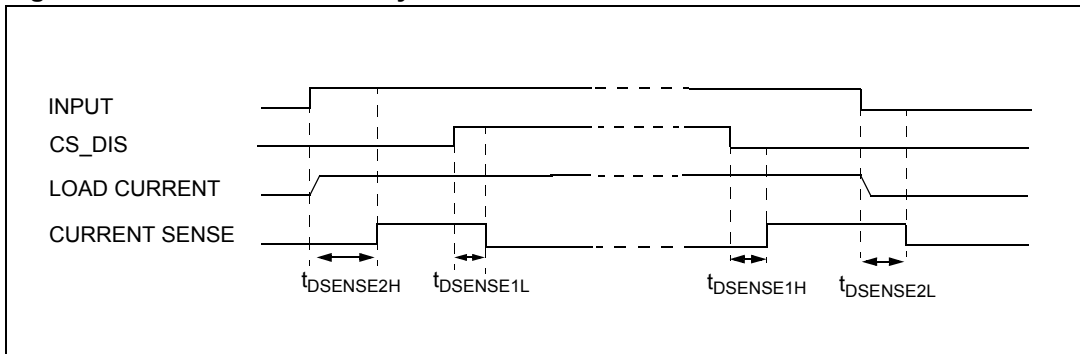

**Figure 5. Open-load OFF-state delay timing**

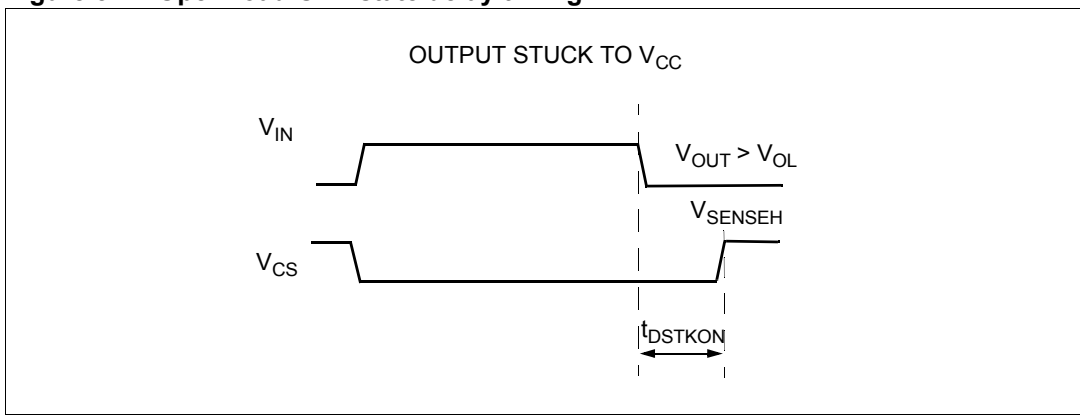

**Figure 6. Switching characteristics**

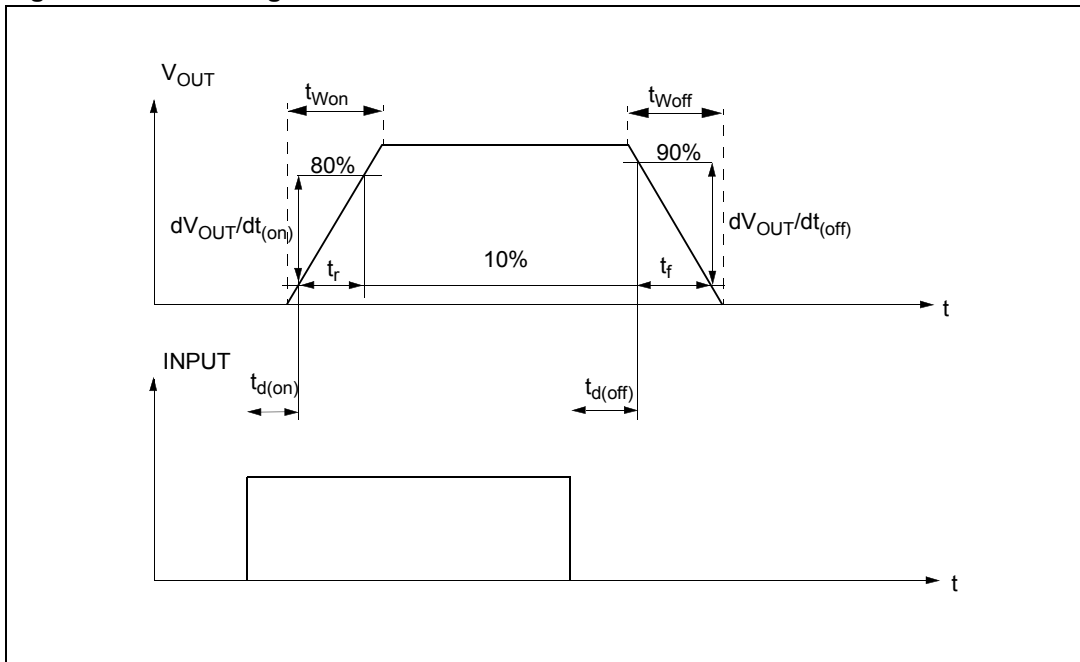

**Figure 7. Delay response time between rising edge of output current and rising edge of current sense (CS enabled)**

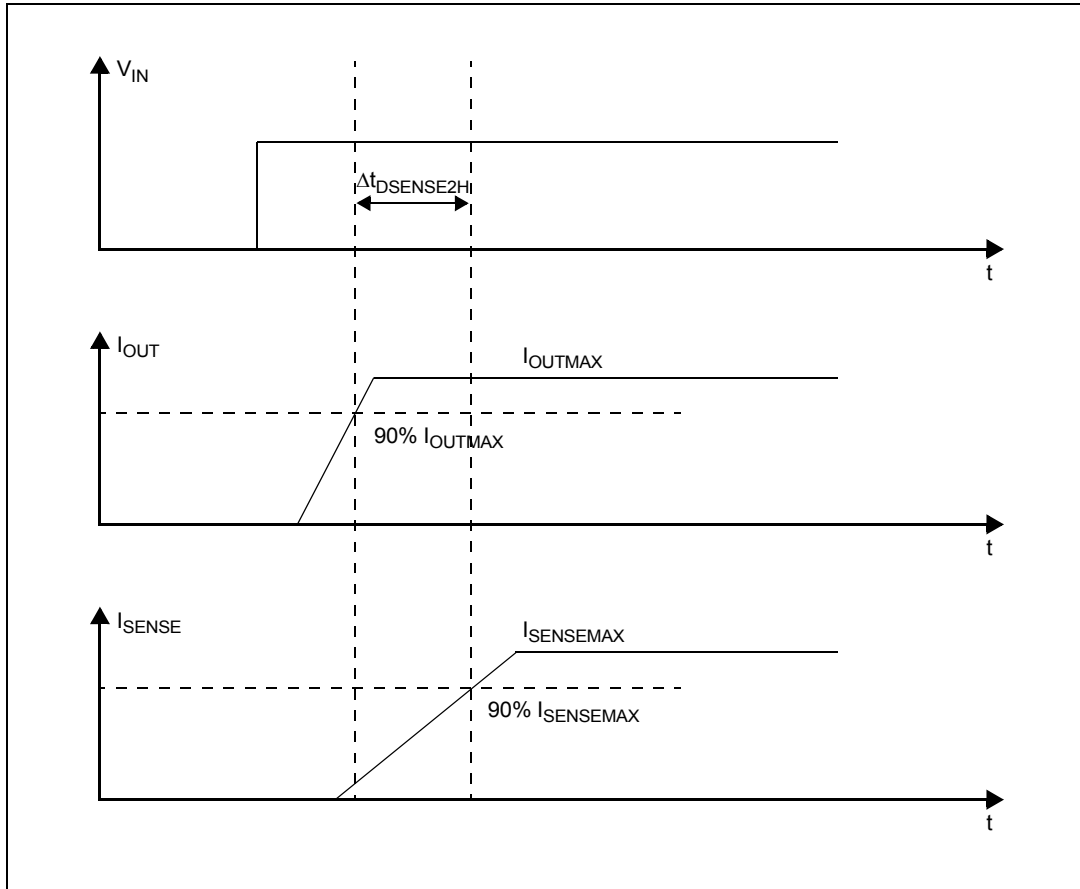

**Figure 8. Output voltage drop limitation**

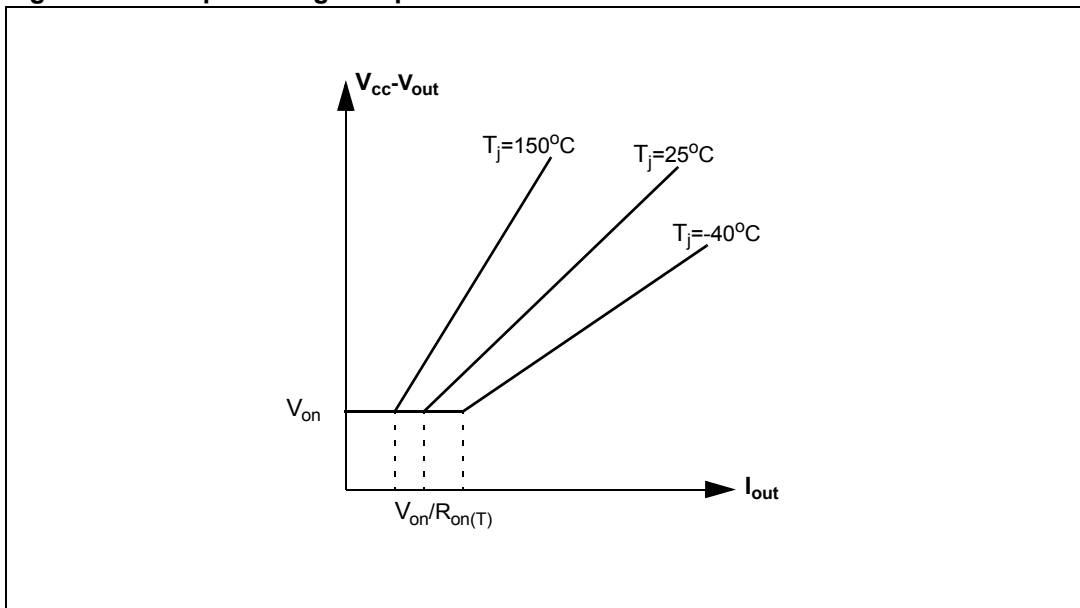

Figure 9.  $I_{OUT}/I_{SENSE}$  vs.  $I_{OUT}$

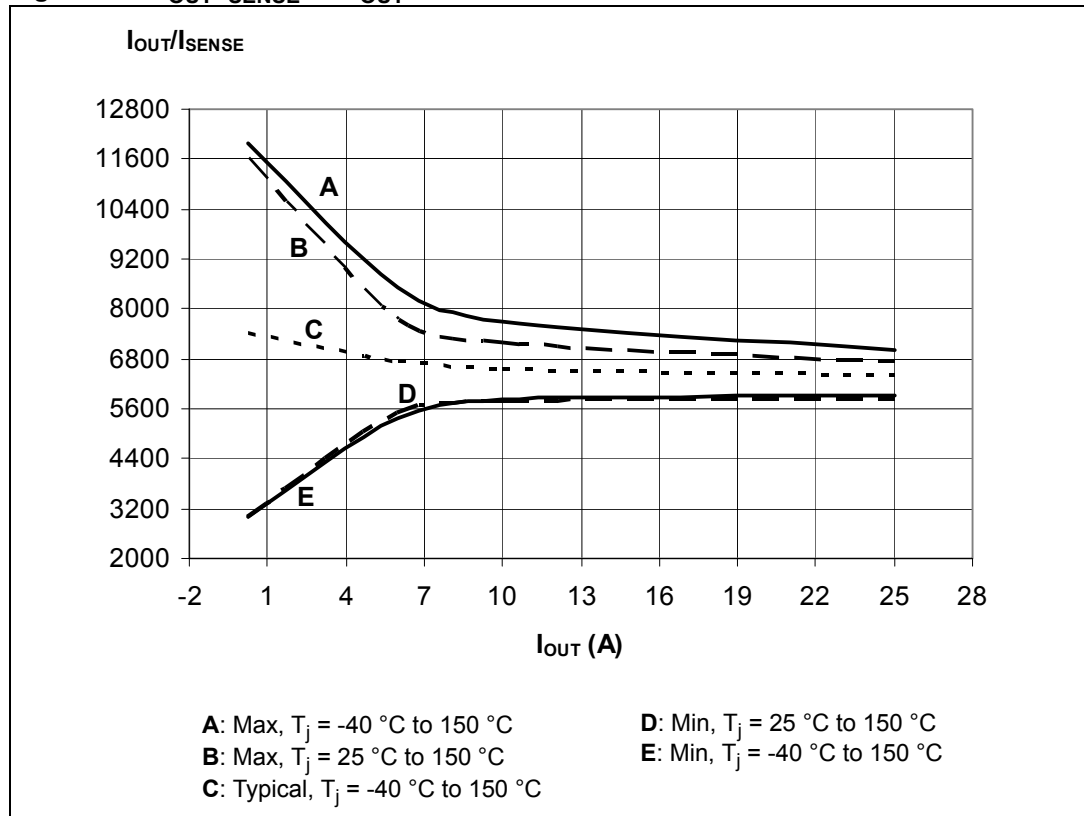
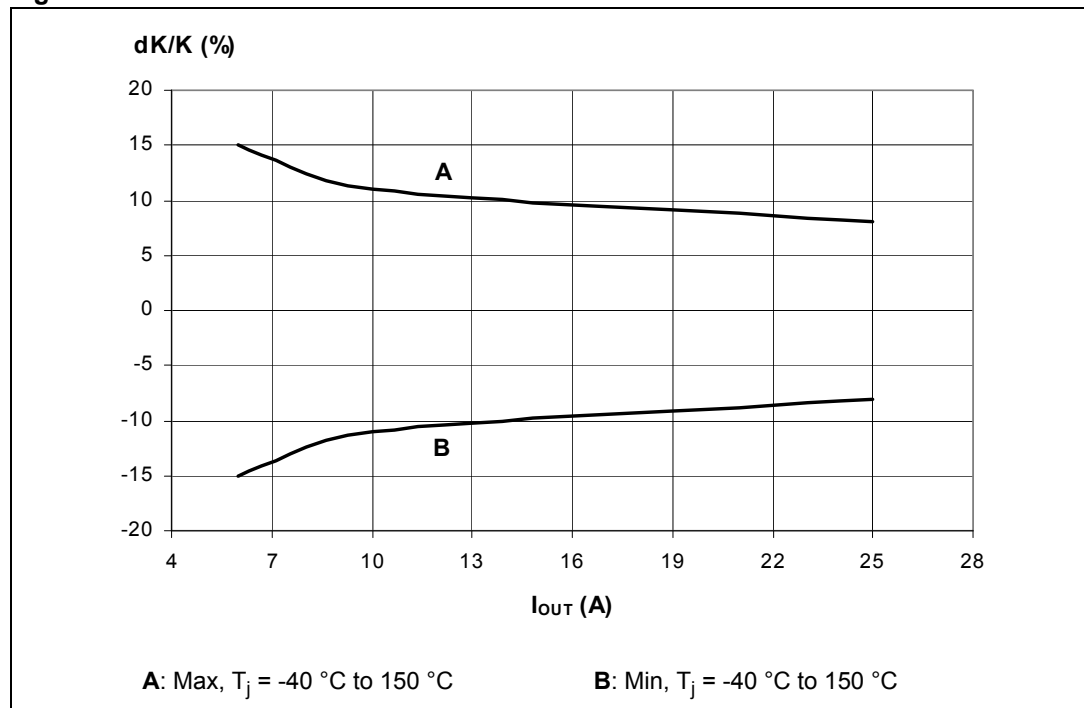

Figure 10. Maximum current sense ratio drift vs. load current<sup>(1)</sup>



1. Parameter guaranteed by design; it is not tested.

Table 11. Truth table

Conditions	Input	Output	SENSE ( $V_{CSD} = 0\text{ V}$ ) <sup>(1)</sup>
Normal operation	L	L	0
	H	H	Nominal
Overtemperature	L	L	0
	H	L	$V_{SENSEH}$
Undervoltage	L	L	0
	H	L	0
Overload	H	X (no power limitation)	Nominal
	H	Cycling (power limitation)	$V_{SENSEH}$
Short-circuit to GND (power limitation)	L	L	0
	H	L	$V_{SENSEH}$
Open load OFF-state (with external pull-up)	L	H	$V_{SENSEH}$
Short-circuit to $V_{CC}$ (external pull-up disconnected)	L	H	$V_{SENSEH}$
	H	H	$V_{SENSEH}$ < Nominal
Negative output voltage clamp	L	L	0

1. If the  $V_{CSD}$  is high, the SENSE output is at a high-impedance, its potential depends on leakage currents and external circuit.



**Table 12. Electrical transient requirements (part 1)**

ISO 7637-2: 2004(E) Test pulse	Test levels <sup>(1)</sup>		Number of pulses or test times	Burst cycle/pulse repetition time		Delays and Impedance
	III	IV		Min.	Max.	
1	-75 V	-100 V	5000 pulses	0.5 s	5 s	2 ms, 10 Ω
2a	+37 V	+50 V	5000 pulses	0.2 s	5 s	50 μs, 2 Ω
3a	-100 V	-150 V	1h	90 ms	100 ms	0.1 μs, 50 Ω
3b	+75 V	+100 V	1h	90 ms	100 ms	0.1 μs, 50 Ω
4	-6 V	-7 V	1 pulse			100 ms, 0.01 Ω
5b <sup>(2)</sup>	+65 V	+87 V	1 pulse			400 ms, 2 Ω

1. The above test levels must be considered referred to  $V_{CC} = 13.5$  V except for pulse 5b.
2. Valid in case of external load dump clamp: 40 V maximum referred to ground.

**Table 13. Electrical transient requirements (part 2)**

ISO 7637-2: 2004(E) Test pulse	Test level results	
	III	IV
1	C	C
2a	C	C
3a	C	C
3b	C	C
4	C	C
5b <sup>(1)</sup>	C	C

1. Valid in case of external load dump clamp: 40V maximum referred to ground.

**Table 14. Electrical transient requirements (part 3)**

Class	Contents
C	All functions of the device are performed as designed after exposure to disturbance.
E	One or more functions of the device are not performed as designed after exposure to disturbance and cannot be returned to proper operation without replacing the device.

## 2.4 Waveforms

Figure 11. Normal operation

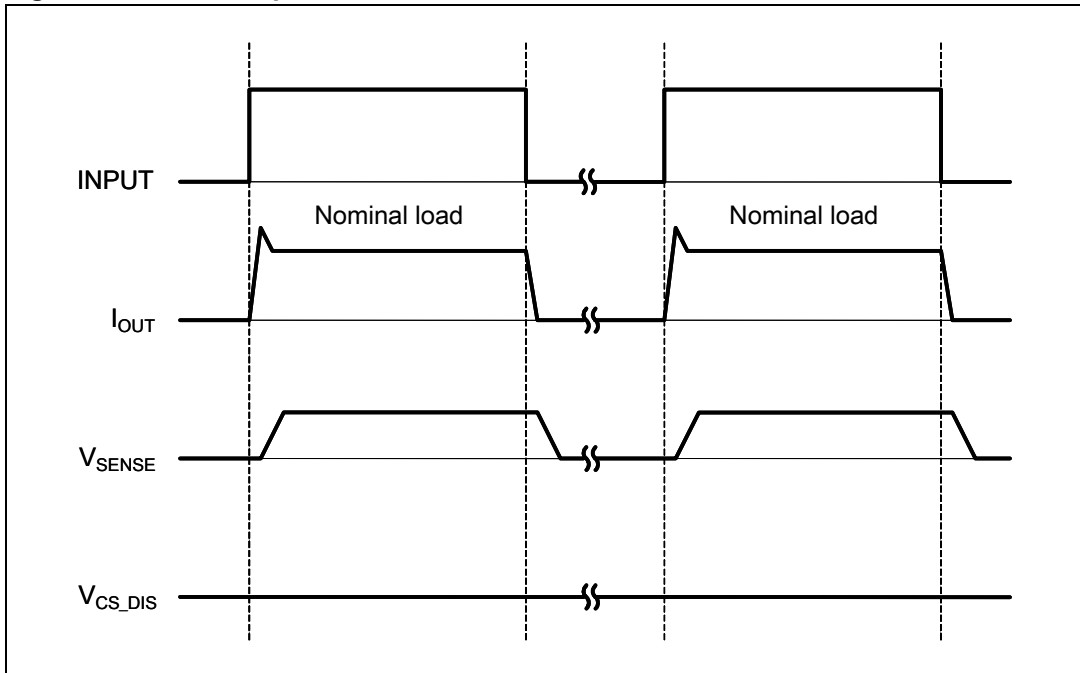

Figure 12. Overload or short to GND

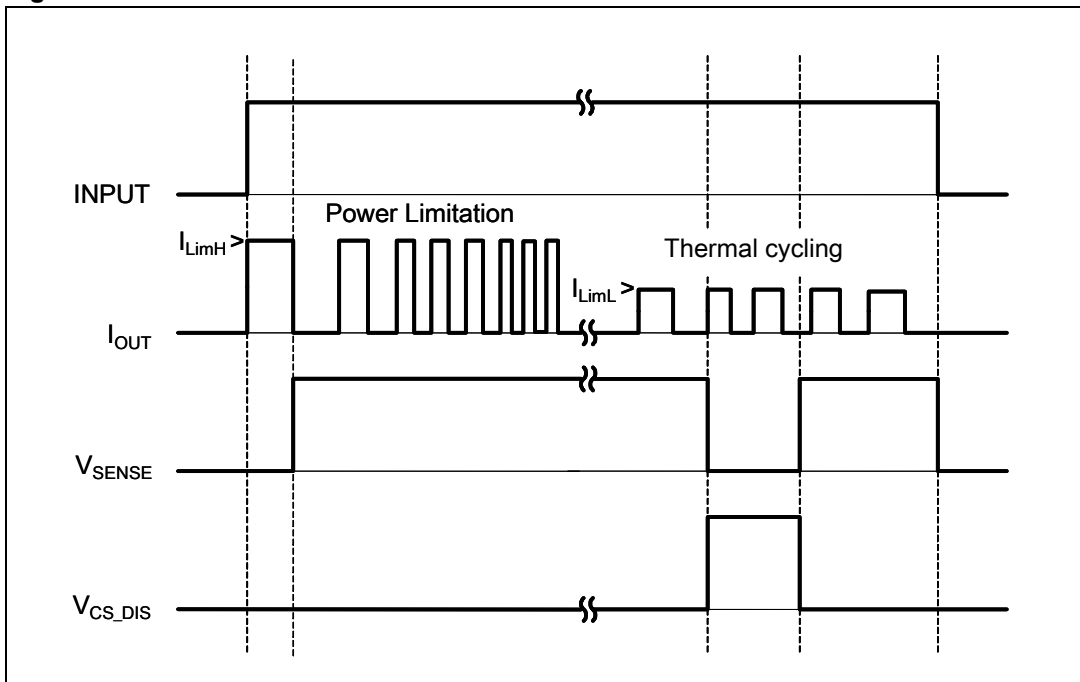

Figure 13. Intermittent overload

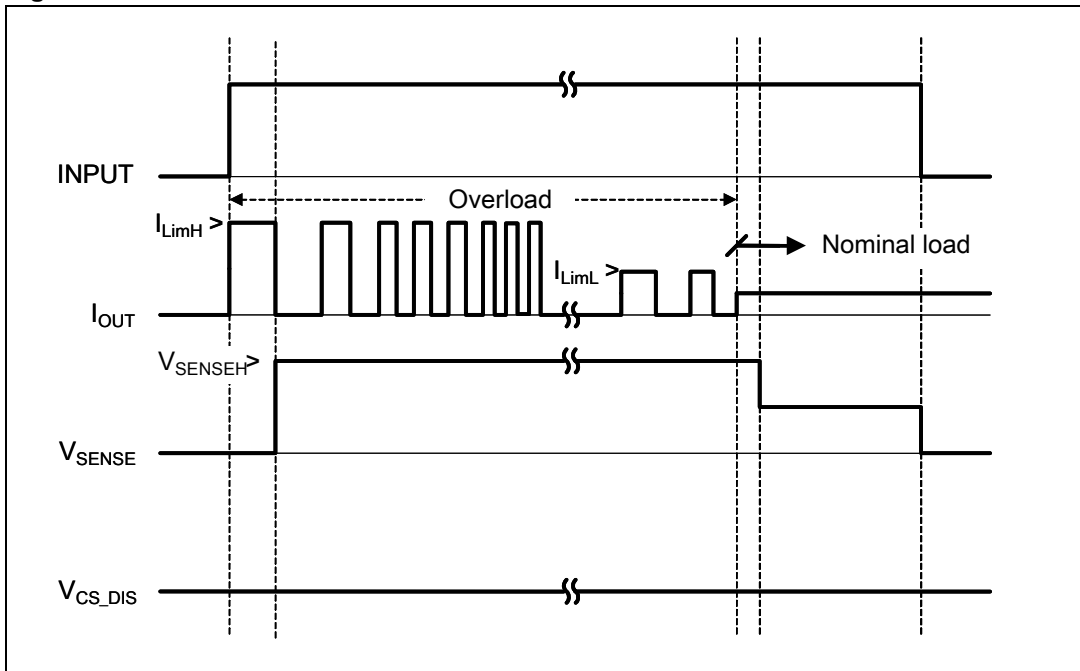

Figure 14. OFF-state open-load with external circuitry

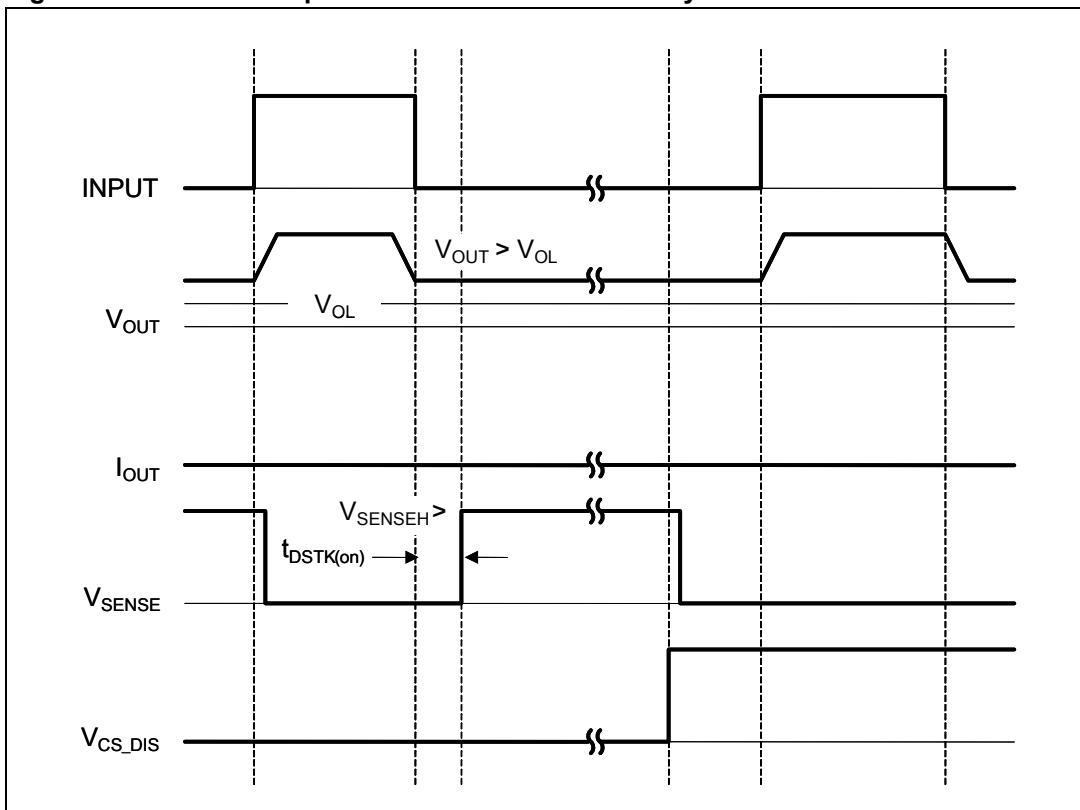

Figure 15. Short to  $V_{CC}$

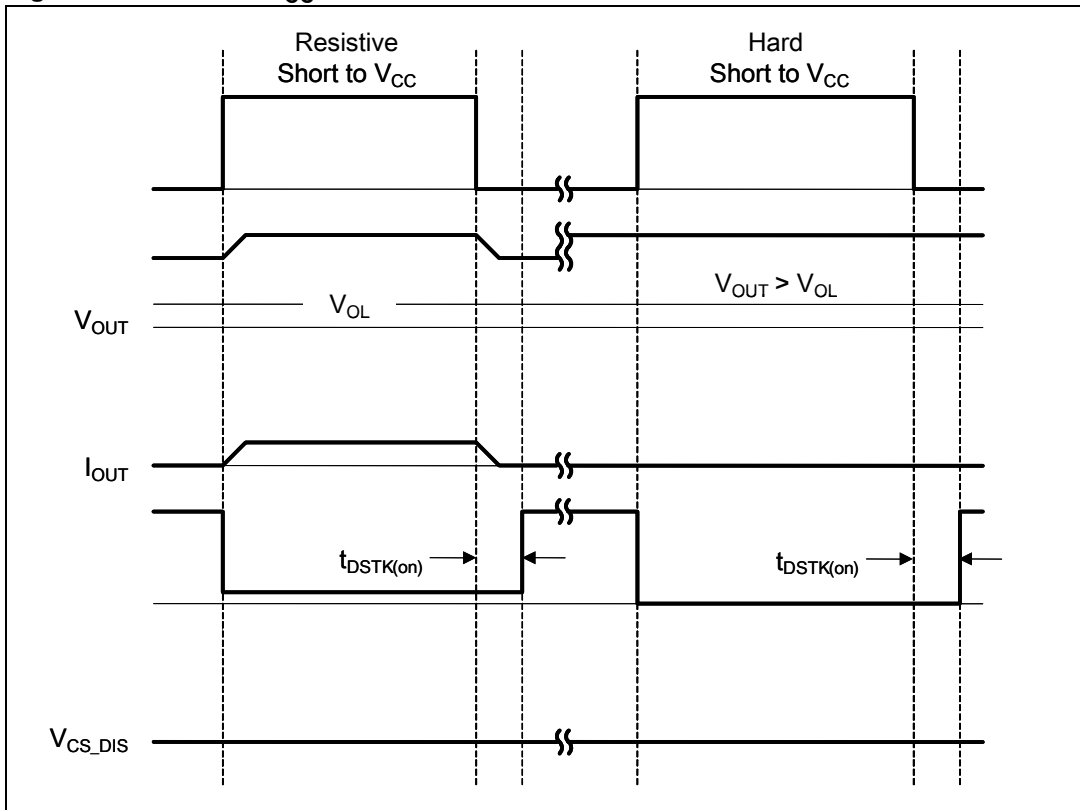
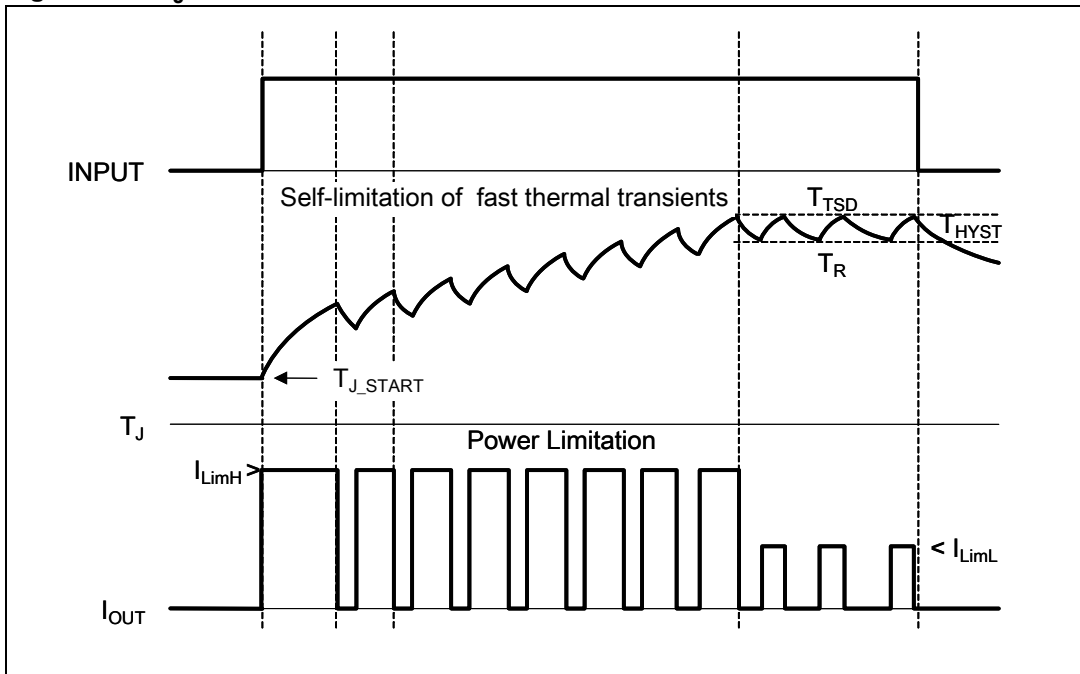

Figure 16.  $T_J$  evolution in overload or short to GND



## 2.5 Electrical characteristics curves

Figure 17. OFF-state output current

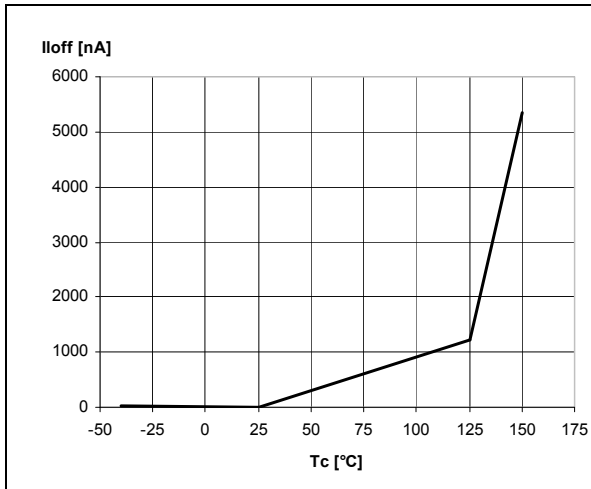

Figure 18. High-level input current

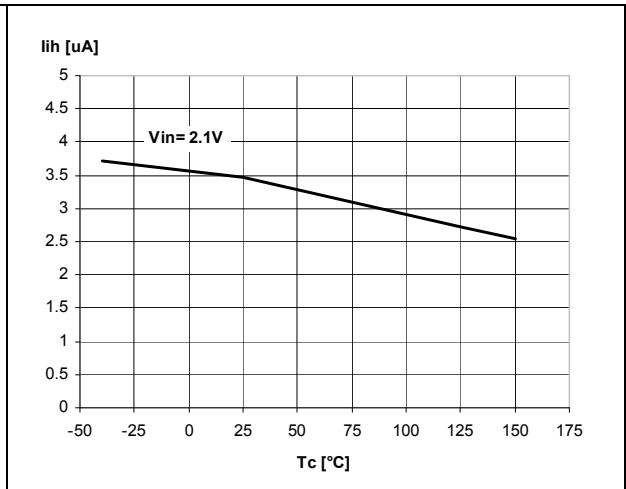

Figure 19. Input clamp voltage

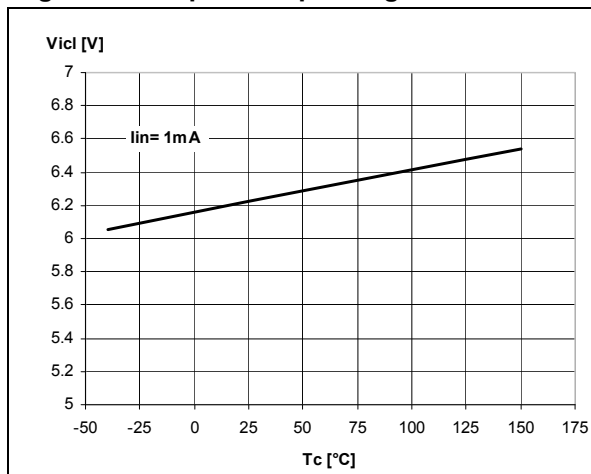

Figure 20. Low-level input voltage

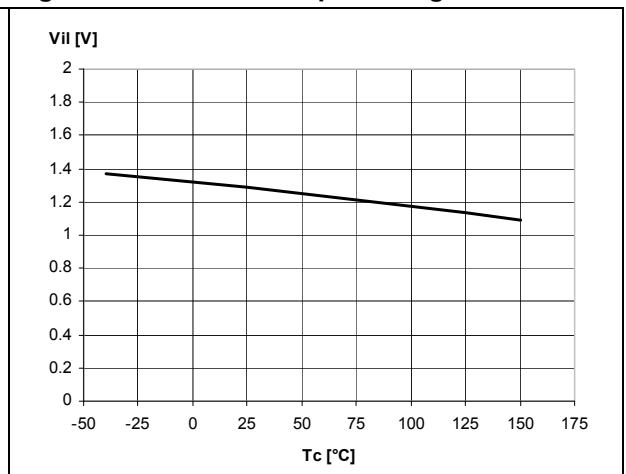

Figure 21. High-level input voltage

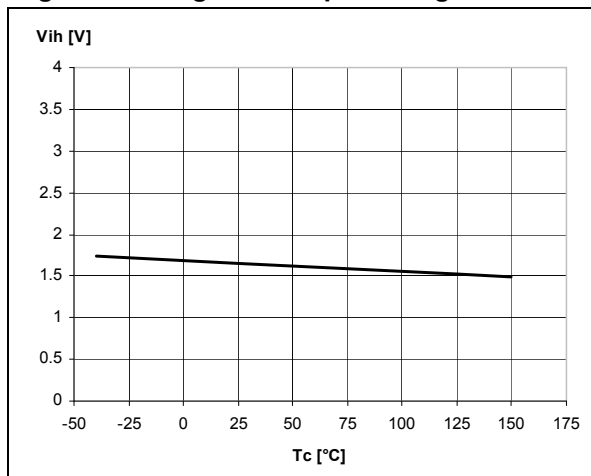

Figure 22. Input hysteresis voltage

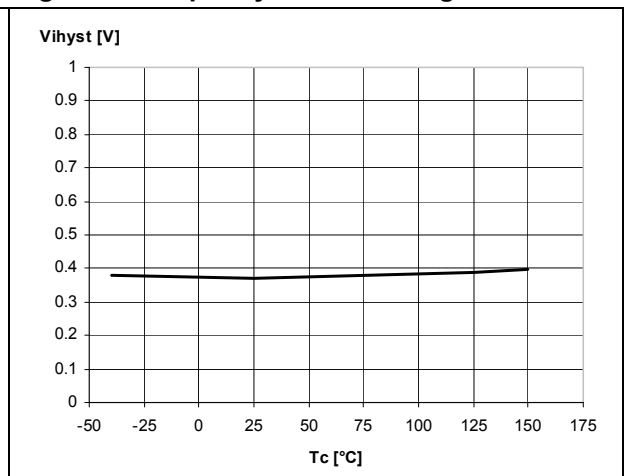

Figure 23. ON-state resistance vs.  $T_{case}$

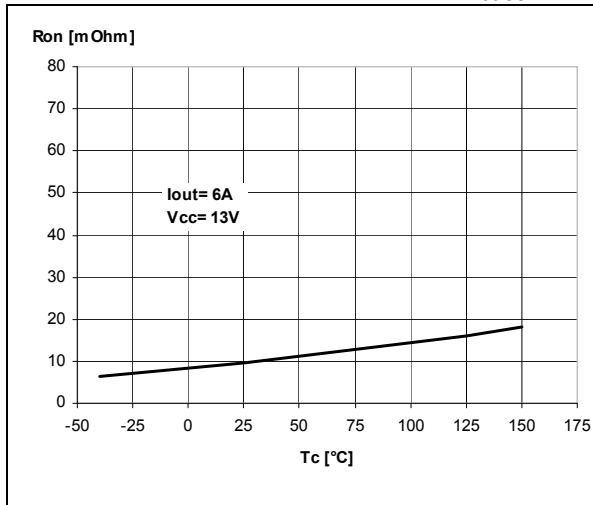

Figure 24. ON-state resistance vs.  $V_{CC}$

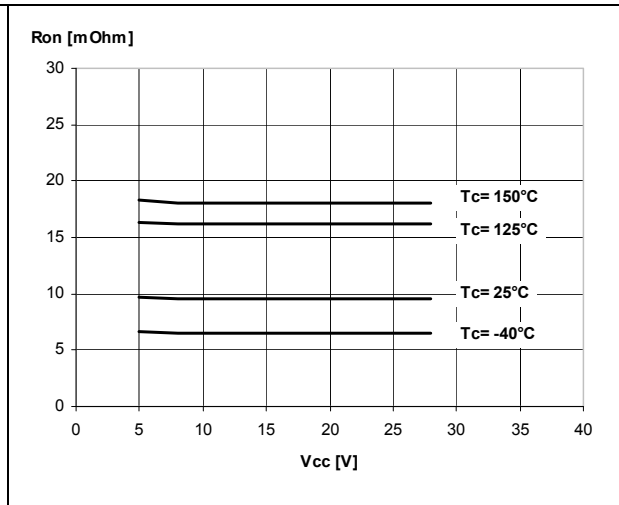

Figure 25. Undervoltage shutdown

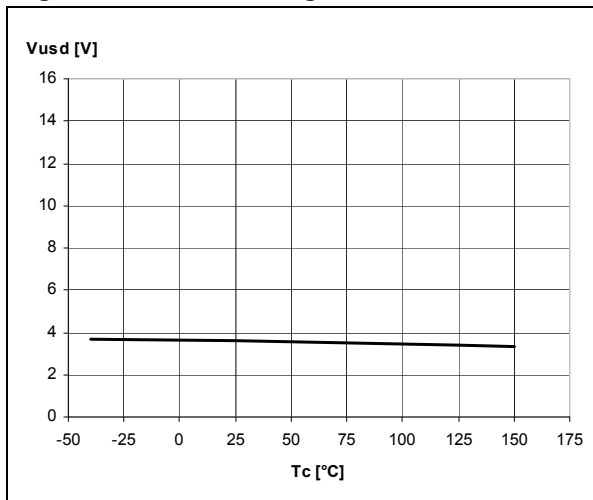

Figure 26. Turn-on voltage slope

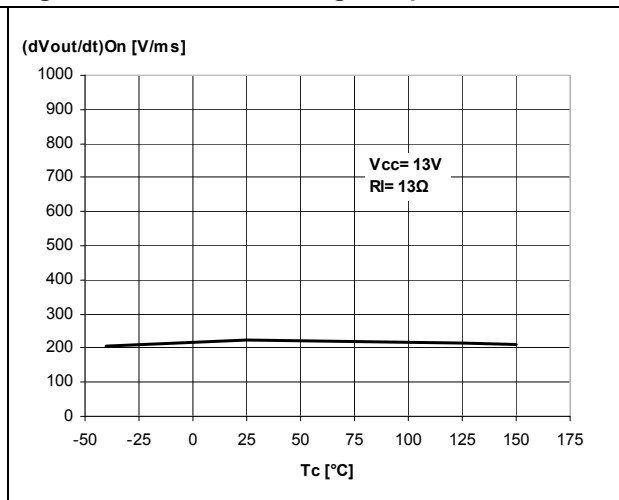

Figure 27.  $I_{LIMH}$  Vs.  $T_{case}$

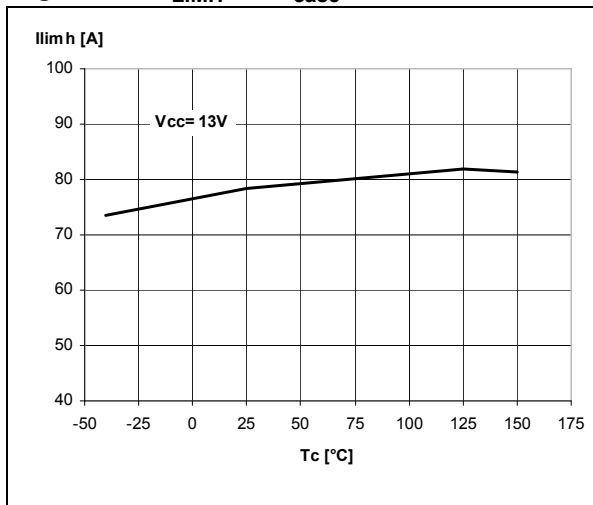

Figure 28. Turn-off voltage slope

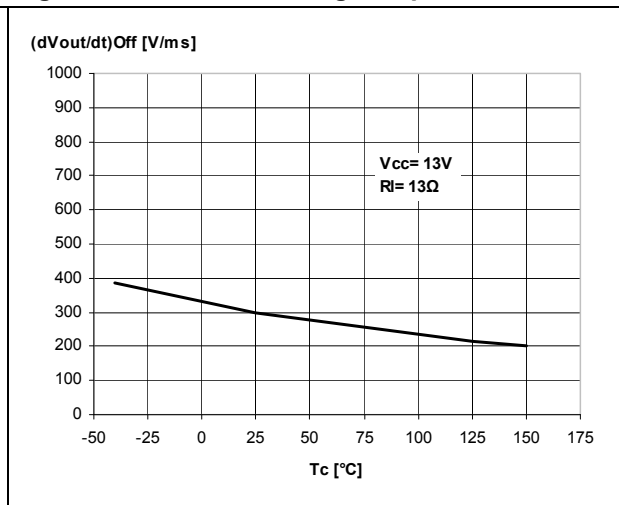

Figure 29. High-level CS\_DIS voltage

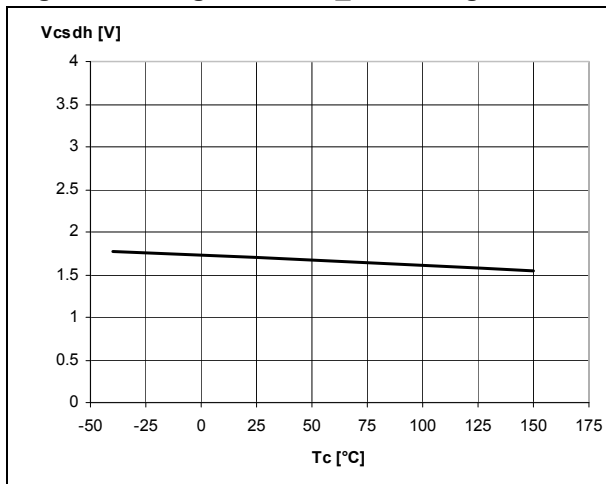

Figure 30. CS\_DIS clamp voltage

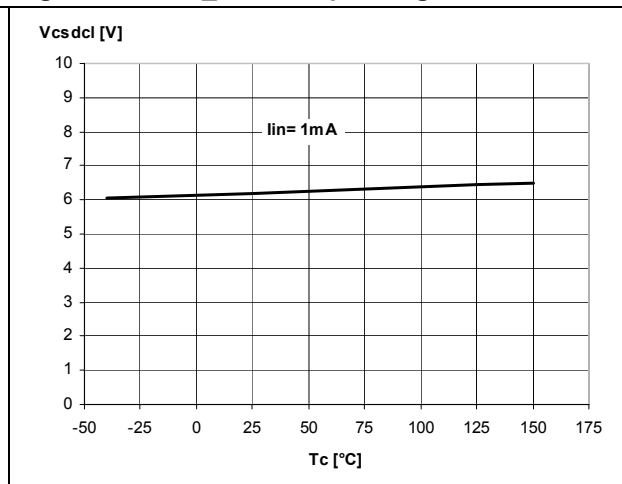
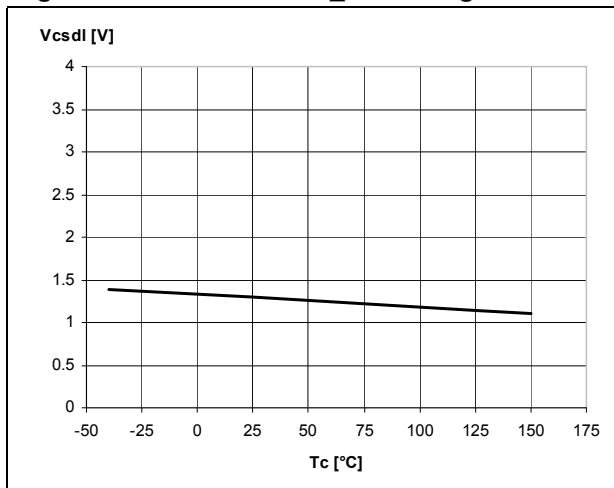
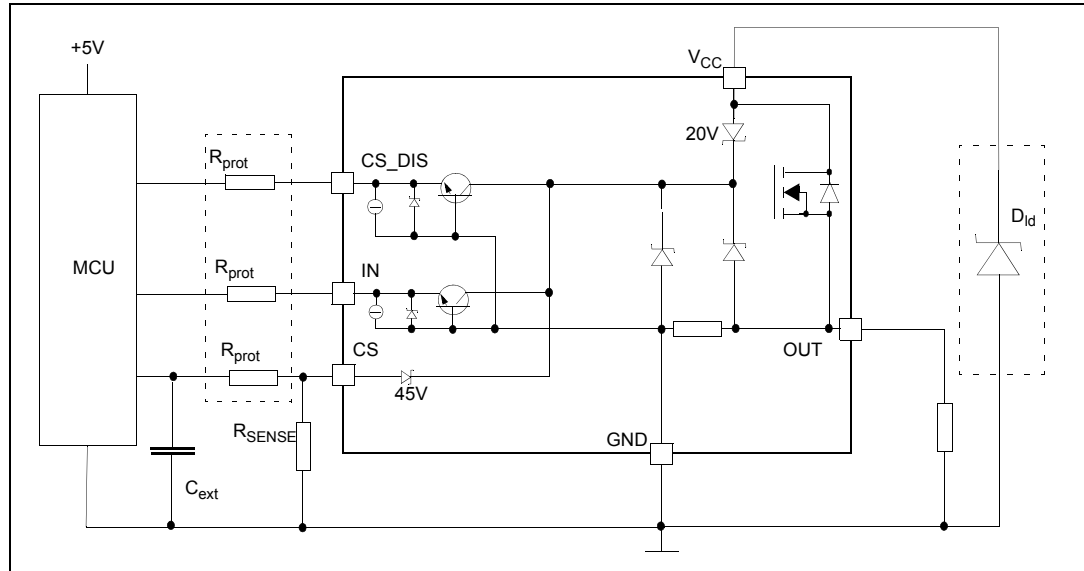

Figure 31. Low-level CS\_DIS voltage



### 3 Application information

Figure 32. Application schematic



#### 3.1 Load dump protection

$D_{ld}$  is necessary (voltage transient suppressor) if the load dump peak voltage exceeds the  $V_{CC}$  max DC rating. The same applies if the device is subject to transients on the  $V_{CC}$  line that are greater than the ones shown in the ISO 7637-2 2004 (E) table.

#### 3.2 MCU I/Os protection

When negative transients are present on the  $V_{CC}$  line, the control pins is pulled negative to approximately -1.5 V. ST suggests to insert a resistor ( $R_{prot}$ ) in line to prevent the microcontroller I/Os pins to latch-up.

The value of these resistors is a compromise between the leakage current of microcontroller and the current required by the HSD I/Os (input levels compatibility) with the latch-up limit of microcontroller I/Os.

##### Equation 1

$$-V_{CCpeak} / I_{latchup} \leq R_{prot} \leq (V_{OH\mu C} - V_{IH}) / I_{IHmax}$$

Calculation example:

For  $V_{CCpeak} = -1.5$  V;  $I_{latchup} \geq 20$  mA;  $V_{OH\mu C} \geq 4.5$  V

$$75 \Omega \leq R_{prot} \leq 240 \text{ k}\Omega.$$

Recommended values:  $R_{prot} = 10$  k $\Omega$ ,  $C_{EXT} = 10$  nF.





### 3.3.1 Short to $V_{CC}$ and OFF-state open-load detection

#### Short to $V_{CC}$

A short-circuit between  $V_{CC}$  and output is indicated by the relevant current sense pin set to  $V_{SENSEH}$  during the device OFF-state. Small or no current is delivered by the current sense during the ON-state depending on the nature of the short-circuit.

#### OFF-state open-load with external circuitry

Detection of an open load in off mode requires an external pull-up resistor  $R_{PU}$  connecting the output to a positive supply voltage  $V_{PU}$ .

It is preferable  $V_{PU}$  to be switched off during the module standby mode in order to avoid the overall standby current consumption to increase in normal conditions, i.e. when load is connected.

An external pull-down resistor  $R_{PD}$  connected between output and GND is mandatory to avoid misdetection in case of floating outputs in OFF-state (see [Figure 33: Current sense and diagnostic](#)).

$R_{PD}$  must be selected in order to ensure  $V_{OUT} < V_{OLmin}$  unless pulled-up by the external circuitry:

#### Equation 2

$$V_{OUT}|_{Pull-up\_OFF} = R_{PD} \cdot I_{L(off2)f} < V_{OLmin} = 2\text{ V}$$

$R_{PD} \leq 22\text{ k}\Omega$  is recommended.

For proper open load detection in OFF-state, the external pull-up resistor must be selected according to the following formula:

#### Equation 3

$$V_{OUT}|_{Pull-up\_ON} = \frac{(R_{PD} \cdot V_{PU}) - (R_{PU} \cdot R_{PD} \cdot I_{L(off2)r})}{(R_{PU} + R_{PD})} > V_{OLmax} = 4\text{ V}$$

For the values of  $V_{OLmin}$ ,  $V_{OLmax}$ ,  $I_{L(off2)r}$  and  $I_{L(off2)f}$  (see [Table 10: Open load detection \(8 V <  \$V\_{CC}\$  < 18 V\)](#)).

### 3.4 Maximum demagnetization energy ( $V_{CC} = 13.5\text{ V}$ )

Figure 34. Maximum turn-off current versus inductance<sup>(1)</sup>

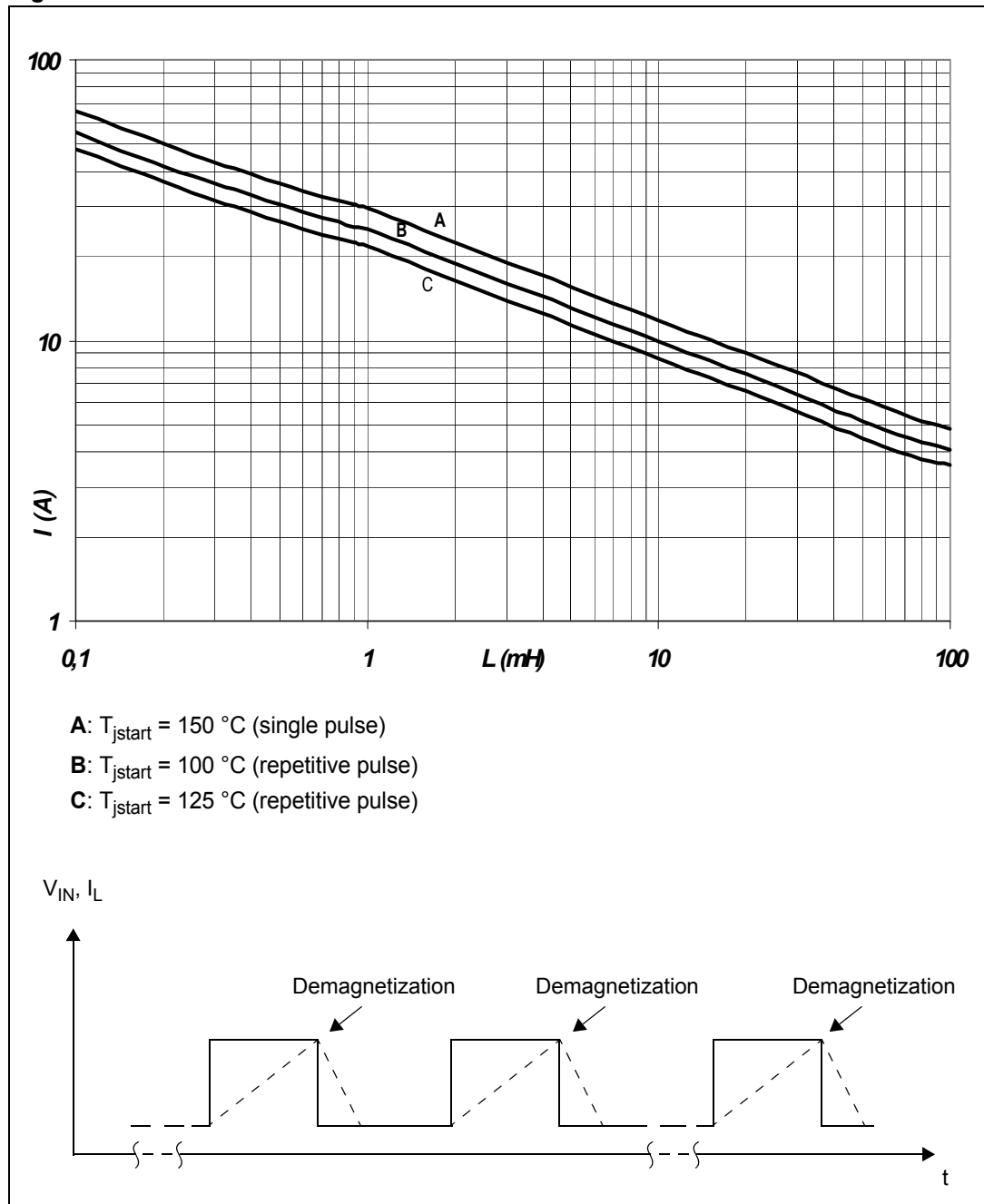

1. Values are generated with  $R_L = 0\ \Omega$ .

In case of repetitive pulses,  $T_{jstart}$  (at beginning of each demagnetization) of every pulse must not exceed the temperature specified above for curves A and B.

## 4 Package and PC board thermal data

### 4.1 HPAK thermal data

Figure 35. PC board<sup>(1)</sup>

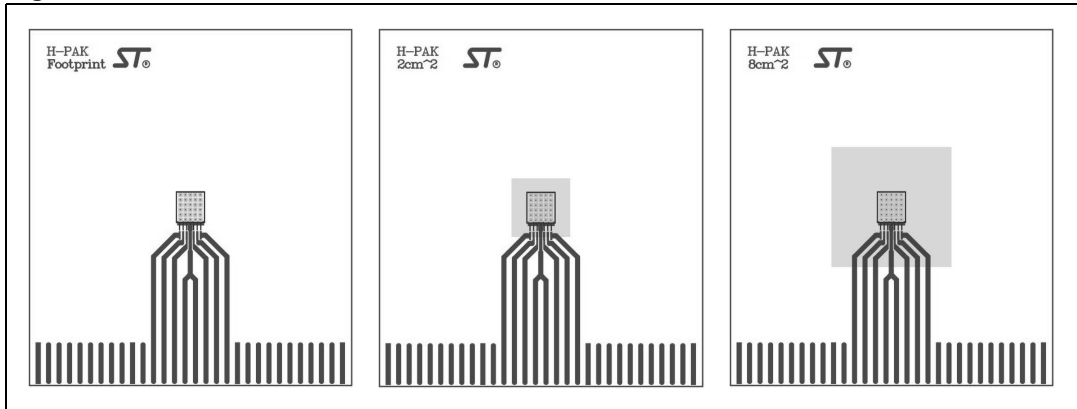

1. Layout condition of  $R_{th}$  and  $Z_{th}$  measurements (PCB FR4 area = 58 mm x 58 mm, PCB thickness = 1.8 mm, Cu thickness = 70  $\mu$ m, Copper areas: from minimum pad lay-out to 8 cm<sup>2</sup>).

Figure 36.  $R_{thj-amb}$  vs. PCB copper area in open box free air condition

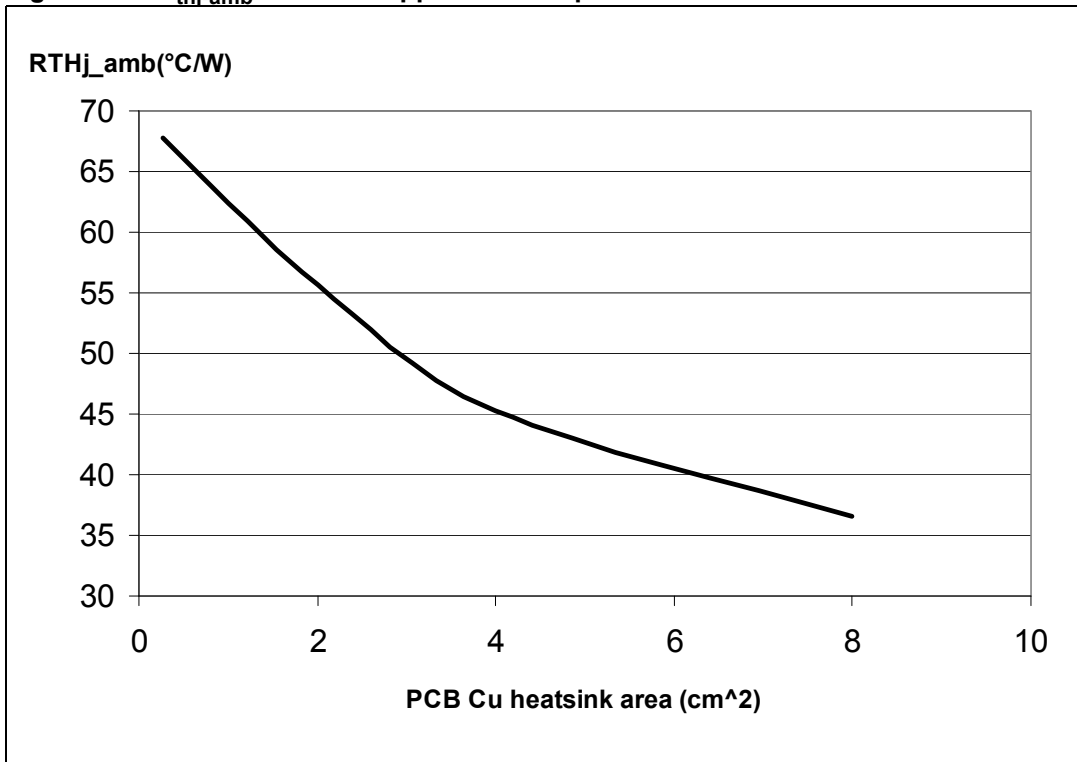

Figure 37. HPAK thermal impedance junction ambient single pulse

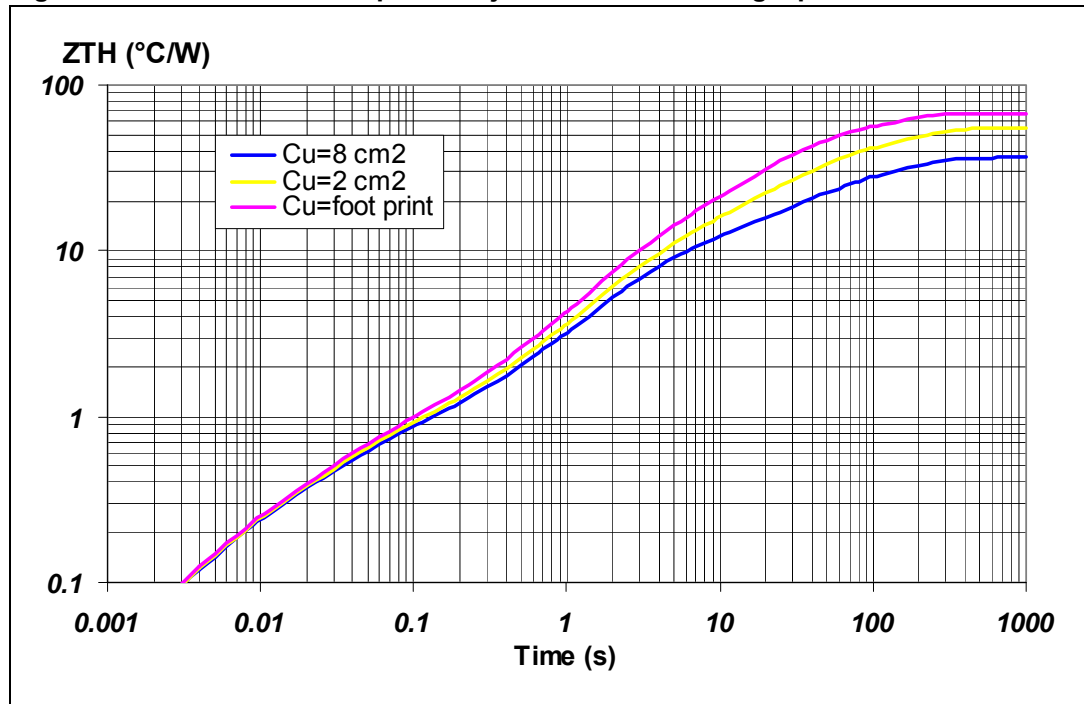
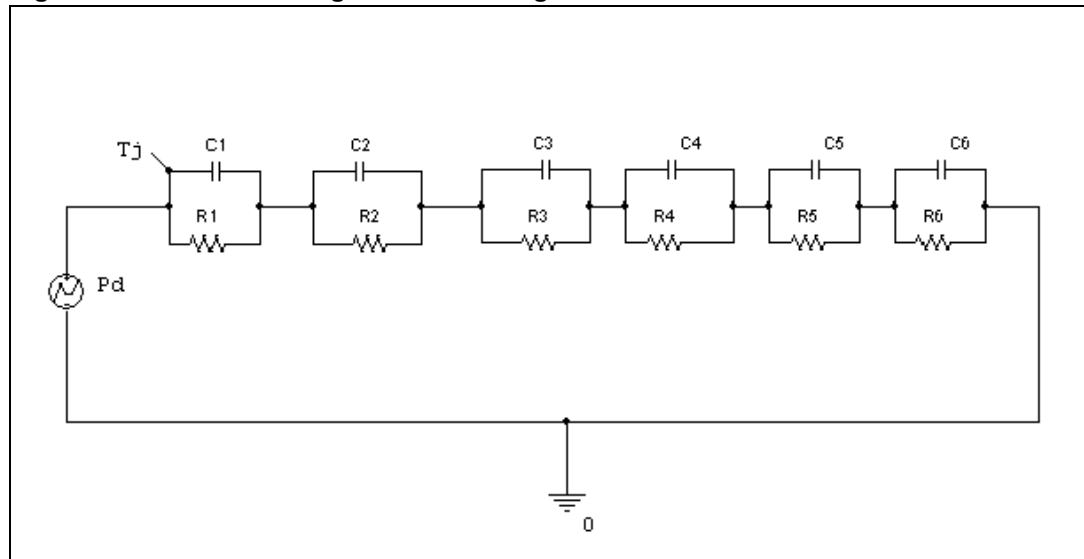

Figure 38. Thermal fitting model of a single-channel HSD in HPAK<sup>(1)</sup>



1. The fitting model is a simplified thermal tool and is valid for transient evolutions where the embedded protections (power limitation or thermal cycling during thermal shutdown) are not triggered.

**Equation 4: pulse calculation formula**

$$Z_{TH\delta} = R_{TH} \cdot \delta + Z_{THtp}(1 - \delta)$$

where  $\delta = t_p/T$

**Table 15. Thermal parameter**

Area/island (cm <sup>2</sup> )	Footprint	4	8
R1 (°C/W)	0.01		
R2 (°C/W)	0.15		
R3 (°C/W)	0.5		
R4 (°C/W)	8		
R5 (°C/W)	28	22	12
R6 (°C/W)	31	25	16
C1 (W.s/°C)	0.005		
C2 (W.s/°C)	0.05		
C3 (W.s/°C)	0.1		
C4 (W.s/°C)	0.4		
C5 (W.s/°C)	0.8	1.4	3
C6 (W.s/°C)	3	6	9

## 5 Package and packing information

### 5.1 ECOPACK®

In order to meet environmental requirements, ST offers these devices in different grades of ECOPACK® packages, depending on their level of environmental compliance. ECOPACK® specifications, grade definitions and product status are available at: [www.st.com](http://www.st.com). ECOPACK® is an ST trademark.

### 5.2 HPAK mechanical data

Figure 39. HPAK package dimension

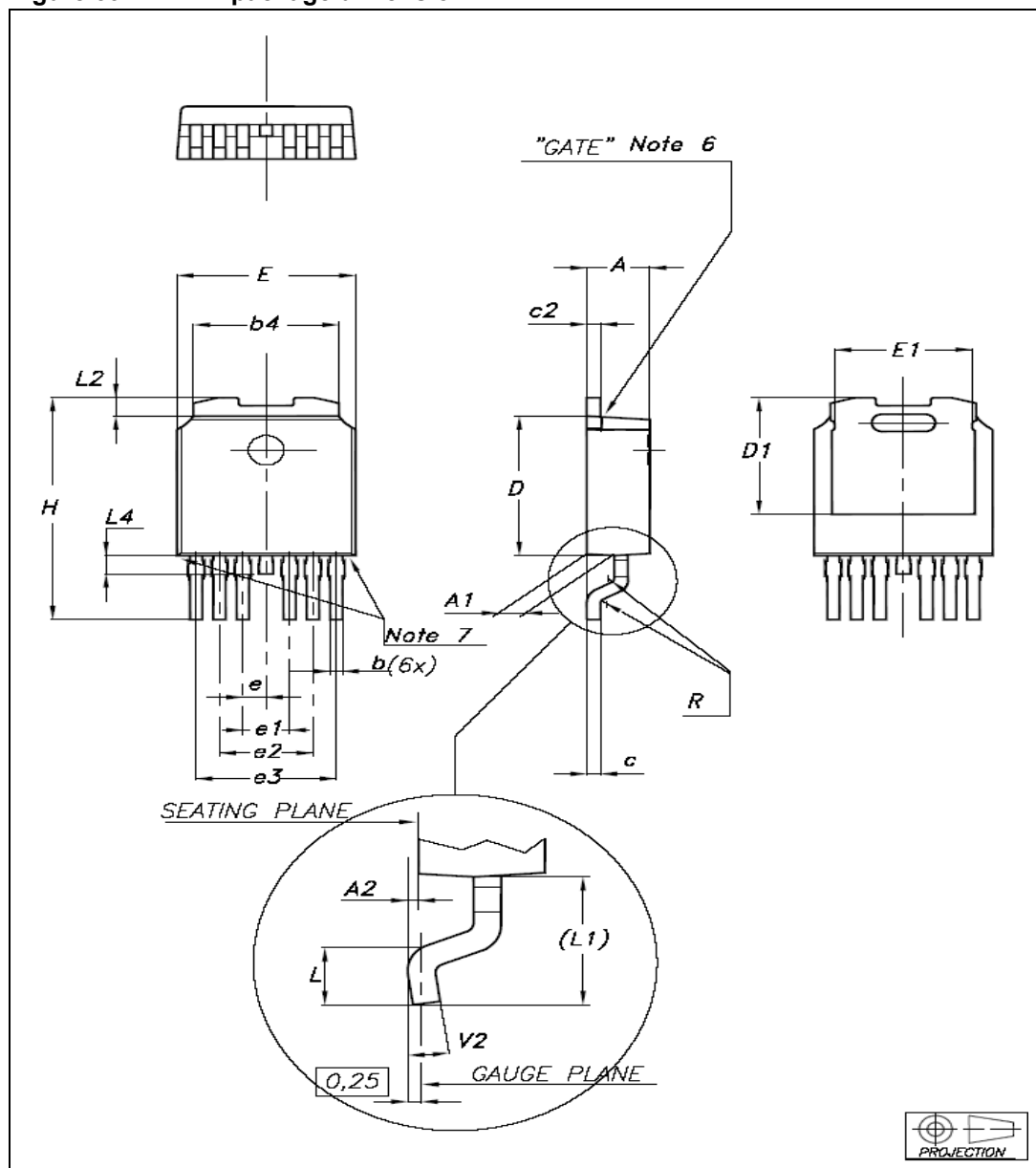

Table 16. HPAK mechanical data

Ref. dim	Data book mm		
	Nom.	Min.	Max.
A		2.20	2.40
A1		0.90	1.10
A2		0.03	0.23
b		0.40	0.55
b4		5.20	5.40
c		0.45	0.60
c2		0.48	0.60
D		6.00	6.20
D1	5.10		
E		6.40	6.60
E1	5.20		
e	0.85		
e1		1.60	1.80
e2		3.30	3.50
e3		5.00	5.20
H		9.35	10.10
L		1	
(L1)	2.80		
L2	0.80		
L4		0.60	1.00
R	0.20		
V2		0°	8°



### 5.3 HPAK suggested land pattern

Figure 40. HPAK suggested pad layout<sup>(1)</sup>

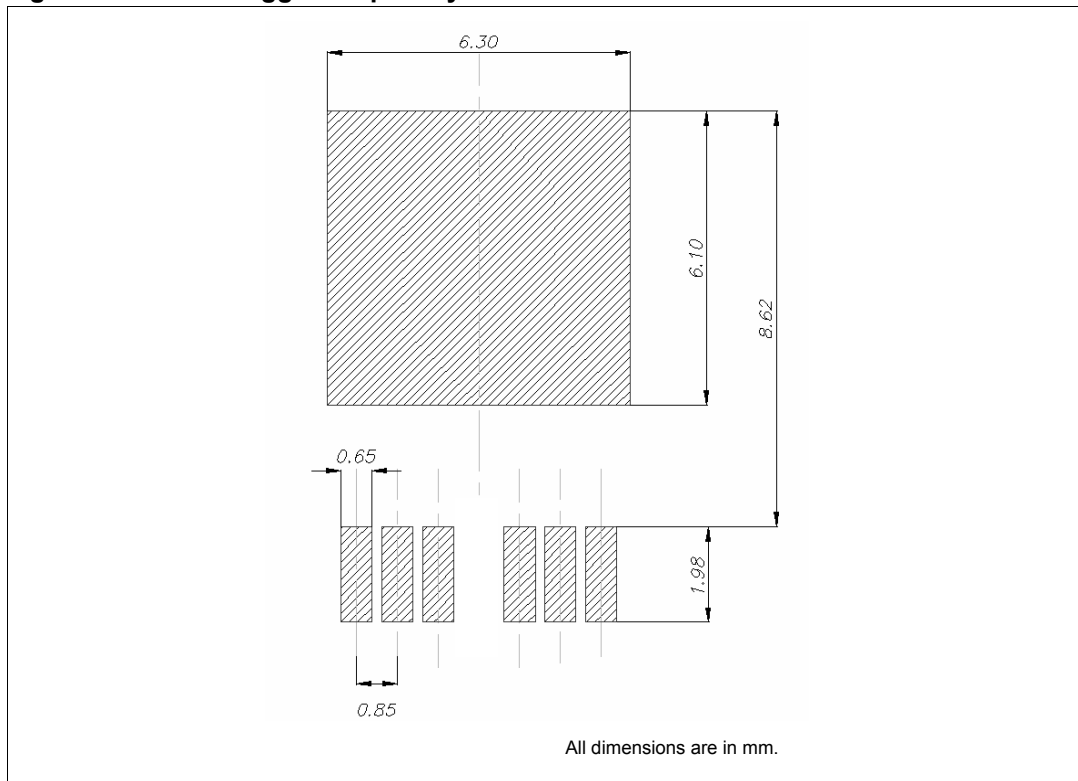

1. The land pattern proposed is not intended to overrule User's PCB design, manufacturing and soldering process rules

### 5.4 Packing information

The devices can be packed in tube or tape and reel shipments (see [Table 17: Device summary](#)).

**Figure 41. HPAK tube shipment (no suffix)**

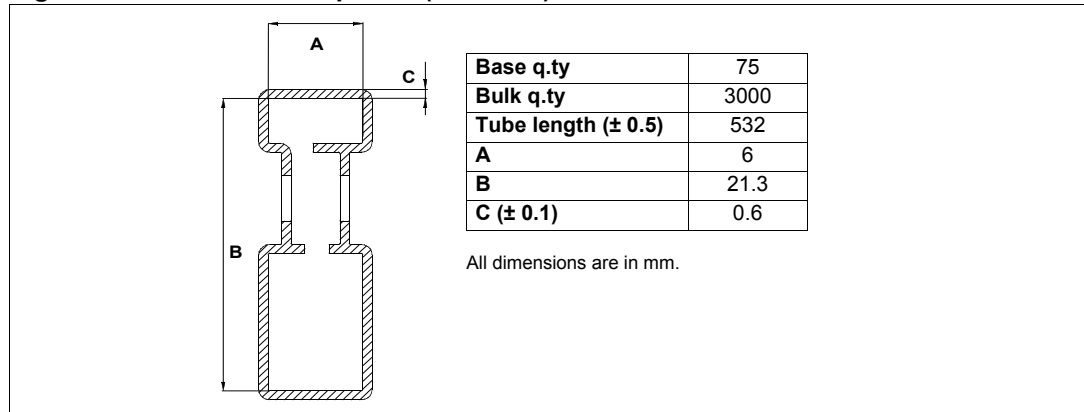

**Figure 42. HPAK tape and reel (suffix “TR”)**

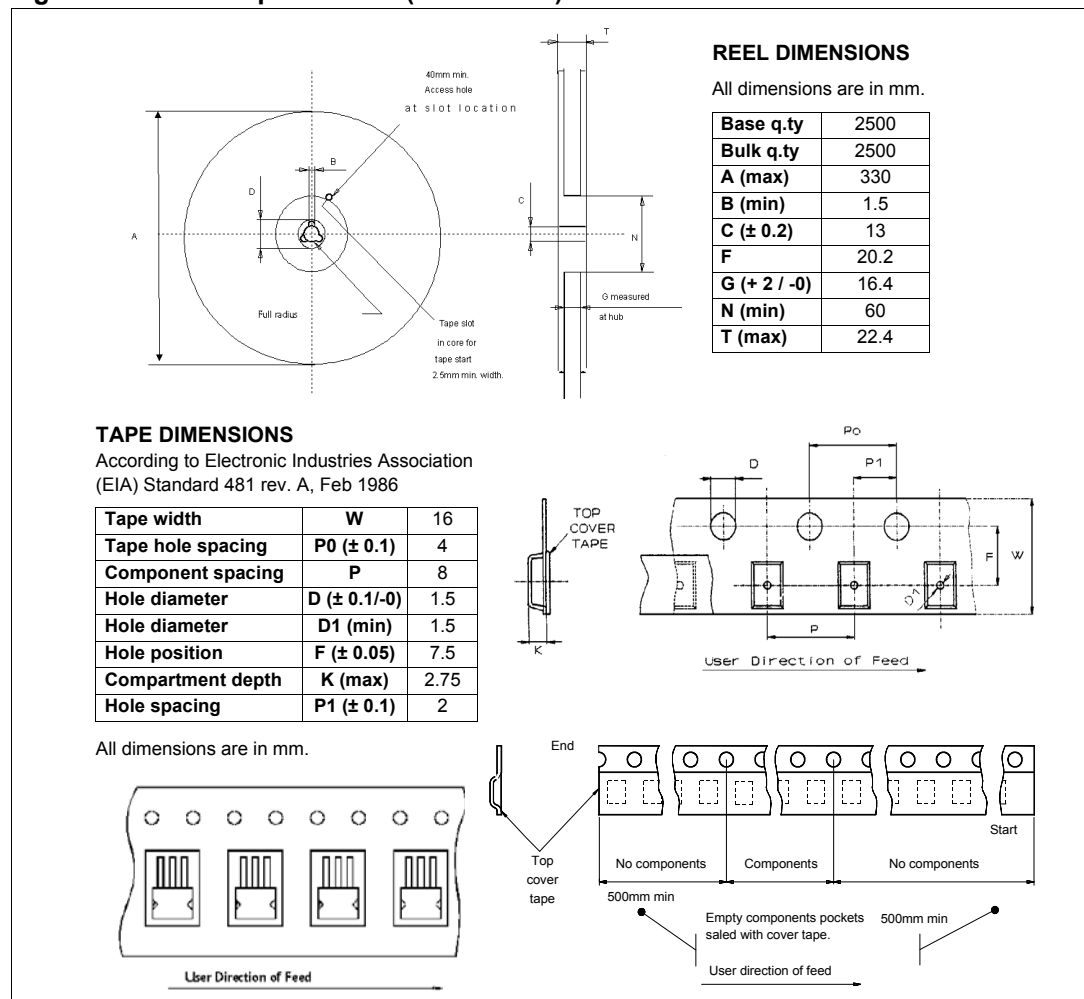

## 6 Order codes

Table 17. Device summary

Package	Order codes	
	Tube	Tape and reel
6 pins HPAK	VN5E010AH-E	VN5E010AHTR-E

## 7 Revision history

**Table 18. Document revision history**

Date	Revision	Changes
2-Jul-2009	1	Initial release.
02-Oct-2009	2	Updated <a href="#">Table 10: Open load detection (8 V &lt; VCC &lt; 18 V)</a> .
19-Sep-2013	3	Updated Disclaimer.

**Please Read Carefully:**

Information in this document is provided solely in connection with ST products. STMicroelectronics NV and its subsidiaries ("ST") reserve the right to make changes, corrections, modifications or improvements, to this document, and the products and services described herein at any time, without notice.

All ST products are sold pursuant to ST's terms and conditions of sale.

Purchasers are solely responsible for the choice, selection and use of the ST products and services described herein, and ST assumes no liability whatsoever relating to the choice, selection or use of the ST products and services described herein.

No license, express or implied, by estoppel or otherwise, to any intellectual property rights is granted under this document. If any part of this document refers to any third party products or services it shall not be deemed a license grant by ST for the use of such third party products or services, or any intellectual property contained therein or considered as a warranty covering the use in any manner whatsoever of such third party products or services or any intellectual property contained therein.

**UNLESS OTHERWISE SET FORTH IN ST'S TERMS AND CONDITIONS OF SALE ST DISCLAIMS ANY EXPRESS OR IMPLIED WARRANTY WITH RESPECT TO THE USE AND/OR SALE OF ST PRODUCTS INCLUDING WITHOUT LIMITATION IMPLIED WARRANTIES OF MERCHANTABILITY, FITNESS FOR A PARTICULAR PURPOSE (AND THEIR EQUIVALENTS UNDER THE LAWS OF ANY JURISDICTION), OR INFRINGEMENT OF ANY PATENT, COPYRIGHT OR OTHER INTELLECTUAL PROPERTY RIGHT.**

**ST PRODUCTS ARE NOT DESIGNED OR AUTHORIZED FOR USE IN: (A) SAFETY CRITICAL APPLICATIONS SUCH AS LIFE SUPPORTING, ACTIVE IMPLANTED DEVICES OR SYSTEMS WITH PRODUCT FUNCTIONAL SAFETY REQUIREMENTS; (B) AERONAUTIC APPLICATIONS; (C) AUTOMOTIVE APPLICATIONS OR ENVIRONMENTS, AND/OR (D) AEROSPACE APPLICATIONS OR ENVIRONMENTS. WHERE ST PRODUCTS ARE NOT DESIGNED FOR SUCH USE, THE PURCHASER SHALL USE PRODUCTS AT PURCHASER'S SOLE RISK, EVEN IF ST HAS BEEN INFORMED IN WRITING OF SUCH USAGE, UNLESS A PRODUCT IS EXPRESSLY DESIGNATED BY ST AS BEING INTENDED FOR "AUTOMOTIVE, AUTOMOTIVE SAFETY OR MEDICAL" INDUSTRY DOMAINS ACCORDING TO ST PRODUCT DESIGN SPECIFICATIONS. PRODUCTS FORMALLY ESCC, QML OR JAN QUALIFIED ARE DEEMED SUITABLE FOR USE IN AEROSPACE BY THE CORRESPONDING GOVERNMENTAL AGENCY.**

Resale of ST products with provisions different from the statements and/or technical features set forth in this document shall immediately void any warranty granted by ST for the ST product or service described herein and shall not create or extend in any manner whatsoever, any liability of ST.

ST and the ST logo are trademarks or registered trademarks of ST in various countries.

Information in this document supersedes and replaces all information previously supplied.

The ST logo is a registered trademark of STMicroelectronics. All other names are the property of their respective owners.

© 2013 STMicroelectronics - All rights reserved

STMicroelectronics group of companies

Australia - Belgium - Brazil - Canada - China - Czech Republic - Finland - France - Germany - Hong Kong - India - Israel - Italy - Japan - Malaysia - Malta - Morocco - Philippines - Singapore - Spain - Sweden - Switzerland - United Kingdom - United States of America

[www.st.com](http://www.st.com)