

## THREE CHANNELS HIGH SIDE SMART SOLID STATE RELAY

TYPE	Channel	R <sub>DS(on)</sub>	I <sub>OUT</sub>	V <sub>CC</sub>
VN450	1 & 2	40 m Ω	10 A	36 V
	3	300 m Ω	2 A	36 V

- OUTPUT CURRENT (CONTINUOUS):  
10 A (CHANNEL 1,2) @ T<sub>C</sub> = 25 ° C  
2 A (CHANNEL 3) @ T<sub>C</sub> = 25 ° C
- 5 V LOGIC LEVEL COMPATIBLE INPUTS
- UNDER VOLTAGE SHUT-DOWN
- OVER VOLTAGE SHUT-DOWN
- THERMAL SHUT-DOWN
- OPEN DRAIN DIAGNOSTIC OUTPUTS
- VERY LOW STAND-BY POWER DISSIPATION

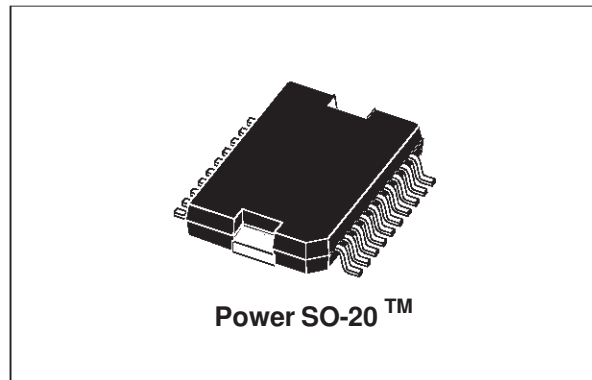

### DESCRIPTION

The VN450 is a monolithic device made using SGS-THOMSON Vertical Intelligent Power Technology, intended for driving resistive or inductive loads with one side connected to ground. This device has three independent channels and three diagnostics.

Built-in thermal shut-down protects the chip from over temperature and short circuit.

The control inputs are 5V CMOS logic level compatible.

The open drain diagnostic outputs indicate short circuit (no load) and overtemperature status.

### BLOCK DIAGRAM

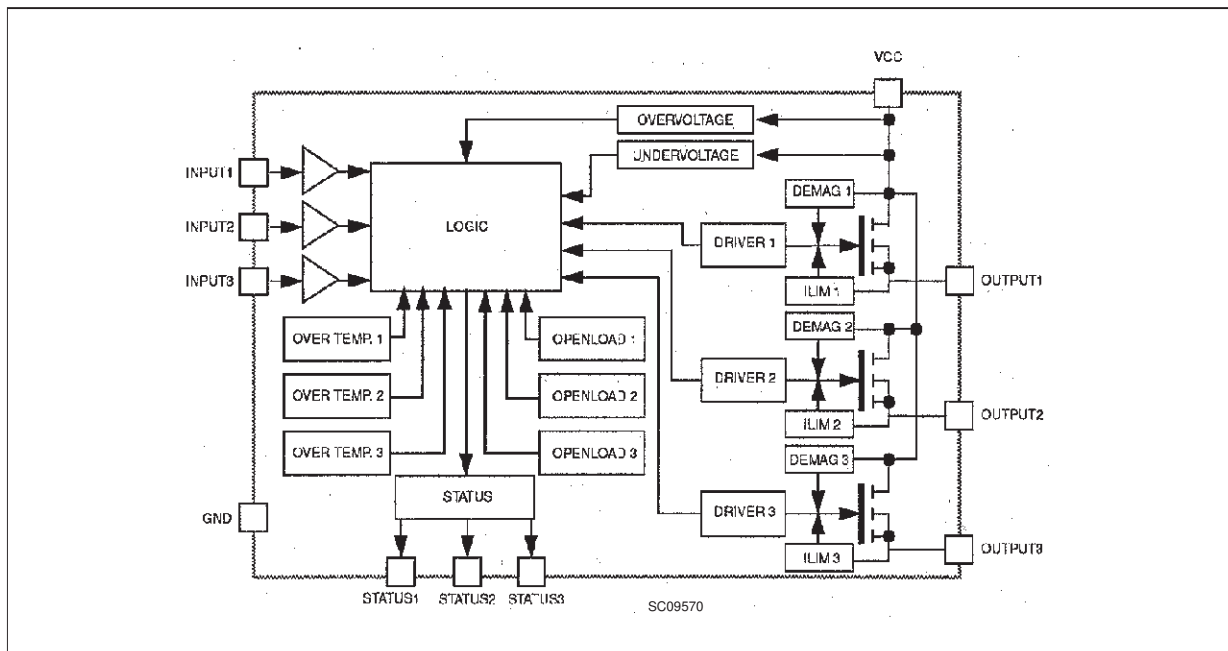

**ABSOLUTE MAXIMUM RATING**

Symbol	Parameter	Value	Unit
$V_{CC}$	Supply Voltage (continuous)	45	V
$-V_{CC}$	Reverse Supply Voltage (continuous)	-0.3	V
$-I_{gnd}$	Reverse Ground Current	-200	mA
$I_{OUT\ 1,2}$	Output Current (continuous), channels 1, 2	10	A
$I_{OUT\ 3}$	Output Current (continuous), channel 3	2.5	A
$I_{R\ 1,2}$	Reverse Output Current (continuous) channels 1, 2	-10	A
$I_{R\ 3}$	Reverse Output Current (continuous) channel 3	-2.5	A
$I_{IN\ 1,2,3}$	Input Current	$\pm 10$	mA
$I_{STAT\ 1,2,3}$	Status Output Current	$\pm 10$	mA
$V_{ESD}$	Electrostatic Discharge ( $R=1.5\ k\Omega$ , $C=100\ pF$ )	2000	V
$P_{tot}$	Power Dissipation at $T_c \leq 25\ ^\circ C$	95	W
$T_j$	Junction Operating Temperature	-40 to 150	$^\circ C$
$T_{stg}$	Storage Temperature	-55 to 150	$^\circ C$

**CONNECTION DIAGRAM**

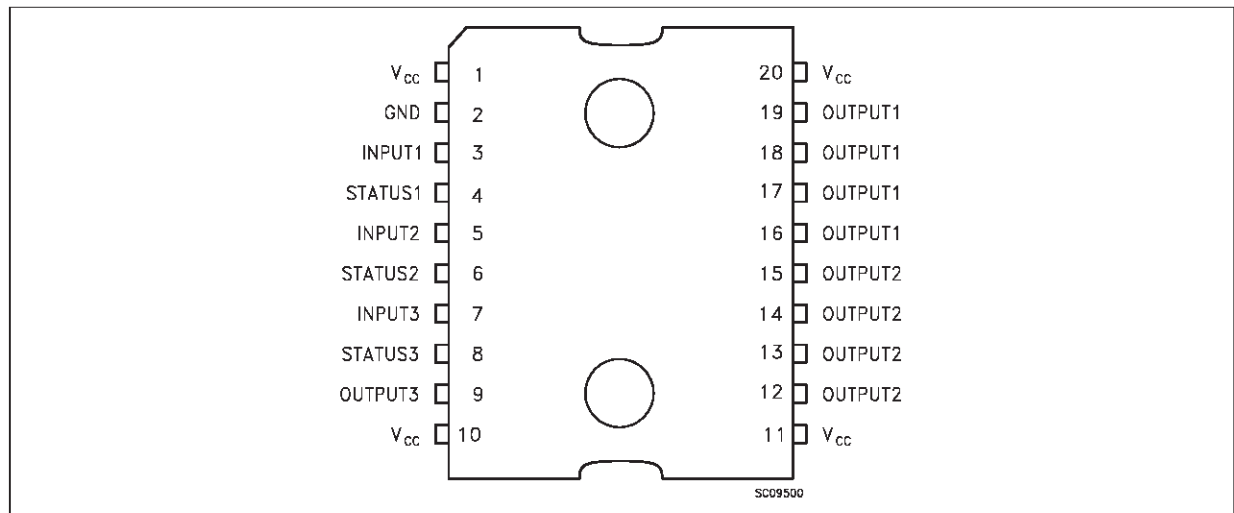

**CURRENT AND VOLTAGE CONVENTIONS**

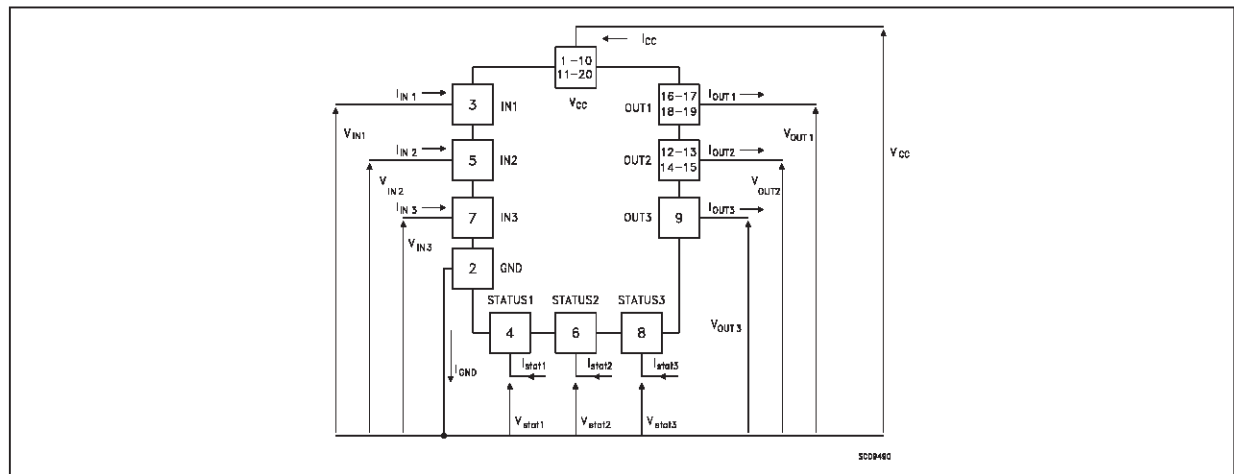

## ELECTRICAL TRANSIENTS REQUIREMENTS

ISO T/R 7637/1 Test Pulse	TEST LEVELS				
	I	II	III	IV	Delays and Impedance
1	-25 V	-50 V	-75 V	-100 V	2 ms, 10 $\Omega$
2	+25 V	+50 V	+75 V	+100 V	0.2 ms, 10 $\Omega$
3a	-25 V	-50 V	-100 V	-150 V	0.1 $\mu$ s, 50 $\Omega$
3b	+25 V	+50 V	+75 V	+100 V	0.1 $\mu$ s, 50 $\Omega$
4	-4 V	-5 V	-6 V	-7 V	100 ms, 0.01 $\Omega$
5	+26.5 V	+46.5 V	+66.5 V	+86.5 V	400 ms, 2 $\Omega$

ISO T/R 7637/1 Test Pulse	TEST LEVELS RESULTS				
	I	II	III	IV	
1	C	C	C	C	
2	C	C	C	C	
3a	C	C	C	C	
3b	C	C	C	C	
4	C	C	C	C	
5	C	E	E	E	

(With a series resistor  $\geq 1$  K $\Omega$  in input and status pins).

CLASS	CONTENTS
C	All function of the device are performed as designed after exposure to disturbance.
E	One or more functions of the device is not performed as designed after exposure and cannot be returned to proper operation without replacing the device.

**THERMAL DATA**

R <sub>thj-case</sub>	Thermal Resistance Junction-case (1)	Max	1.3	°C/W
R <sub>thj-amb</sub>	Thermal Resistance Junction-ambient	Max	50	°C/W

**ELECTRICAL CHARACTERISTICS** (V<sub>CC</sub> = 13 V; -40 °C < T<sub>j</sub> < 125 °C unless otherwise specified)  
**POWER**

Symbol	Parameter	Test Conditions	Min.	Typ.	Max.	Unit
V <sub>CC</sub>	Operating Supply Voltage		5.5	13	36	V
V <sub>USD</sub>	Under Voltage Shut-Down		3	4	5.5	V
V <sub>OV</sub>	Overvoltage Shut-Down		36	39	45	V
R <sub>ON</sub>	On State Resistance	I <sub>OUT 1,2</sub> = 2 A      T <sub>j</sub> = 25 °C I <sub>OUT 1,2</sub> = 2 A I <sub>OUT 3</sub> = 0.5 A      T <sub>j</sub> = 25 °C I <sub>OUT 3</sub> = 0.5 A			40 75 300 540	mΩ mΩ mΩ mΩ
I <sub>S</sub>	Supply Current	Off state      T <sub>case</sub> = 25 °C On state		30 4.2	60 10	μA mA

**LOGIC INPUT (Channel1,2,3)**

Symbol	Parameter	Test Conditions	Min.	Typ.	Max.	Unit
V <sub>IL</sub>	Input Low Level Voltage	(*)			1.5	V
V <sub>IH</sub>	Input High Level Voltage (see note 1)	(*)	3.5			V
V <sub>I(hyst.)</sub>	Input Hysteresis Voltage		0.2	0.85	1.5	V
I <sub>IN</sub>	Input Current	V <sub>IN</sub> = 5 V      T <sub>case</sub> = 25 °C			100	μA
V <sub>ICL</sub>	Input Clamp Voltage	I <sub>IN</sub> = 10 mA I <sub>IN</sub> = -10 mA	5	6 -0.7	7	V V

(\*) : The input voltage is internally clamped at 6V about. It is possible to connect this pin to an higher voltage via an external resistor provided the input current does not exceed 10 mA.

**SWITCHING** (V<sub>CC</sub> = 13 V; T<sub>j</sub> = 25 °C; input rise time < 0.1μs)

Symbol	Parameter	Test Conditions	Min.	Typ.	Max.	Unit
t <sub>d(on)</sub>	Turn-on Delay Time Of Output Current	R <sub>1</sub> = 6.5 Ω      Channels 1,2 R <sub>1</sub> = 26 Ω      Channels 3	10 2	40 20	140 70	μs μs
t <sub>r</sub>	Rise Time Of Output Current	R <sub>1</sub> = 6.5 Ω      Channels 1,2 R <sub>1</sub> = 26 Ω      Channels 3	32 8	150 20	300 60	μs μs
t <sub>d(off)</sub>	Turn-off Delay Time Of Output Current	R <sub>1</sub> = 6.5 Ω      Channels 1,2 R <sub>1</sub> = 26 Ω      Channels 3	120 30	300 75	600 150	μs μs
t <sub>f</sub>	Fall Time Of Output Current	R <sub>1</sub> = 6.5 Ω      Channels 1,2 R <sub>1</sub> = 26 Ω      Channels 3	32 8	80 20	160 50	μs μs
di/dt <sub>(on)</sub>	Turn-on Current Slope	R <sub>1</sub> = 6.5 Ω      Channels 1,2 R <sub>1</sub> = 26 Ω      Channels 3		0.02 0.02	0.05 0.05	A/μs A/μs
di/dt <sub>(off)</sub>	Turn-off Current Slope	R <sub>1</sub> = 6.5 Ω      Channels 1,2 R <sub>1</sub> = 26 Ω      Channels 3		0.02 0.02	0.05 0.05	A/μs A/μs

**ELECTRICAL CHARACTERISTICS** (continued)  
**PROTECTIONS AND DIAGNOSTICS**

Symbol	Parameter	Test Conditions	Min.	Typ.	Max.	Unit	
$T_{TSD}$	Thermal Shut-down Temperature		150	170	190	°C	
$T_{TR}$	Thermal Reset Temperature		135			°C	
$T_{RSD}$ (HYST)	Thermal Hysteresis		5	15	30	°C	
$V_{ENOL}$	Output Voltage Authorizing Openload Detection	$8V \leq V_{CC} \leq 36V$	5.2	6.6	8	V	
$I_{OL}$	Open Load Current Level	Channels 1,2 Channels 3	$8V \leq V_{CC} \leq 18V$ $8V \leq V_{CC} \leq 30V$	100 5	450 50	800 100	mA mA
$I_{OV}$	Over Current	$R_1 \leq 10 \text{ m}\Omega$ $R_1 \leq 10 \text{ m}\Omega$	channels 1,2 channel 3	10 2	18 3.5		A A
$I_{AV}$	Average Current in Short Circuit	$R_1 \leq 10 \text{ m}\Omega$ channels 1,2 channel 3	$T_{Case} = 85^\circ\text{C}$		3.4 2		A A
$V_{STAT1,2,3}$	Status Output Voltage	$I_{STAT} = 1.6 \text{ mA}$ (Fault Condition)			0.4	V	
$V_{SCL1,2,3}$	Status Clamp Voltage	$I_{STAT} = 10 \text{ mA}$ $I_{STAT} = -10 \text{ mA}$	5.5	6 -0.7	7	V V	
$t_{POL}$	Status Delay	(*) (see figure 1)	50	300	950	$\mu\text{s}$	
$t_{POVL}$	Status Delay	(*) (see figure 1)			10	$\mu\text{s}$	
$V_{DEMAG}$	Turn-off Output Clamp Voltage	$I_{OUT1} = 2 \text{ A}$ $L = 1 \text{ mH}$ $V_{IN1} = 0$ $I_{OUT2} = 2 \text{ A}$ $L = 1 \text{ mH}$ $V_{IN2} = 0$ $I_{OUT3} = 0.5 \text{ A}$ $L = 1 \text{ mH}$ $V_{IN3} = 0$	$V_{CC}-45$	$V_{CC}-50$	$V_{CC}-55$	V	

(\*) ISO definitions     $T_{POL}$  = Status delay in case of open load conditions  
 $T_{POVL}$  = Status delay in case of over load conditions

FIGURE 1

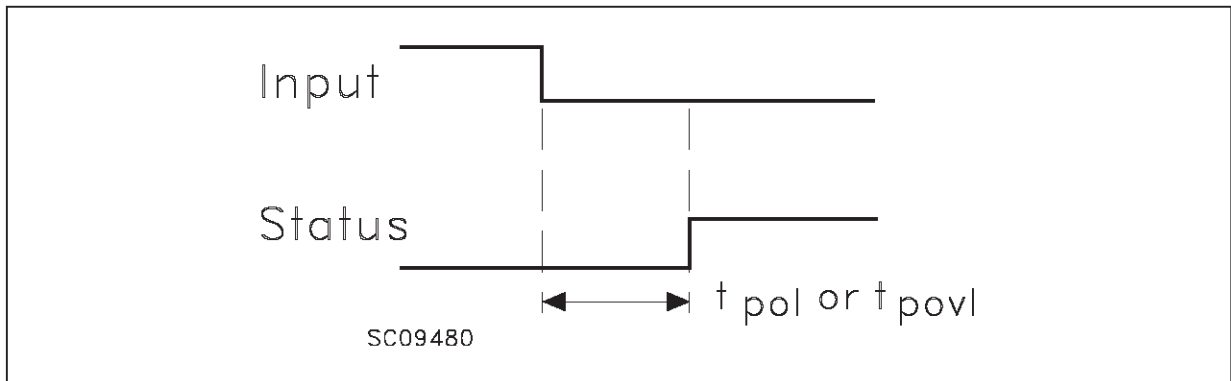

SWITCHING PARAMETERS TEST CONDITIONS

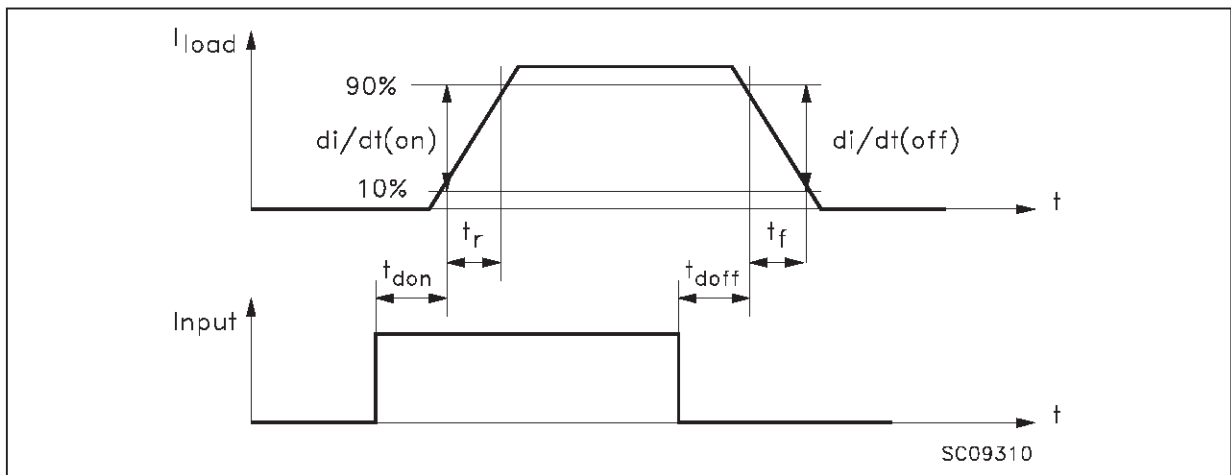

TRUTH TABLE (Channels 1,2,3)

Conditions	INPUT	OUTPUT	STATUS
Normal Operation	L	L	H
	H	H	H
Over-voltage	X	L	H
Under-voltage	X	L	H
Thermal shut-down	H	L	L
Open load	H	H	L

H = high level, L= low level, X= unspecified

FIGURE 2: Switching Waveforms

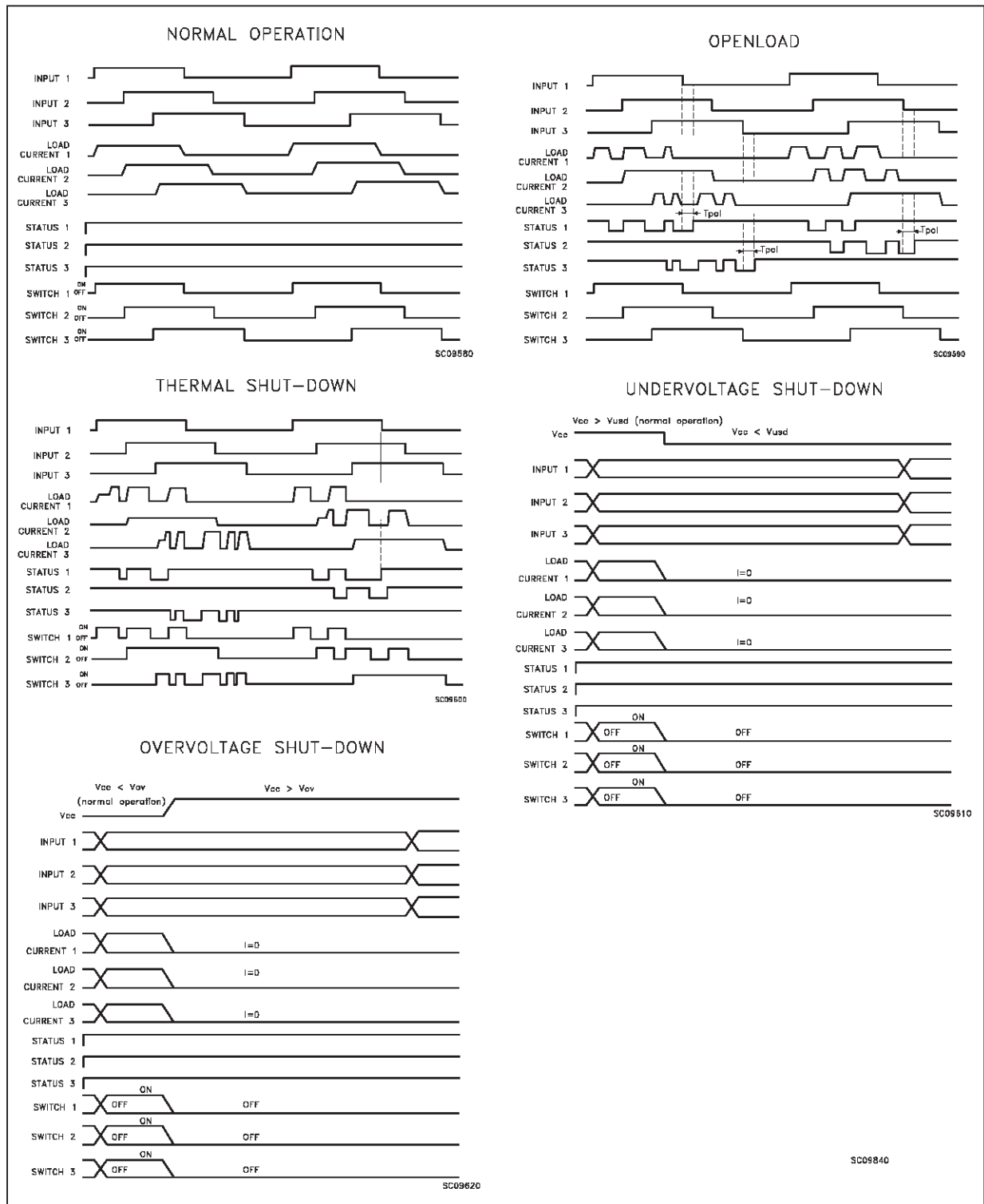

**PowerSO-20 MECHANICAL DATA**

DIM.	mm			inch		
	MIN.	TYP.	MAX.	MIN.	TYP.	MAX.
A			3.60			0.1417
a1	0.10		0.30	0.0039		0.0118
a2			3.30			0.1299
a3	0		0.10	0		0.0039
b	0.40		0.53	0.0157		0.0209
c	0.23		0.32	0.009		0.0126
D (1)	15.80		16.00	0.6220		0.6299
E	13.90		14.50	0.5472		0.570
e		1.27			0.050	
e3		11.43			0.450	
E1 (1)	10.90		11.10	0.4291		0.437
E2			2.90			0.1141
G	0		0.10	0		0.0039
h			1.10			0.0433
L	0.80		1.10	0.0314		0.0433
N	10° (max.)					
S	8° (max.)					
T		10.0			0.3937	

(1) "D and E1" do not include mold flash or protusions  
 - Mold flash or protusions shall not exceed 0.15mm (0.006")

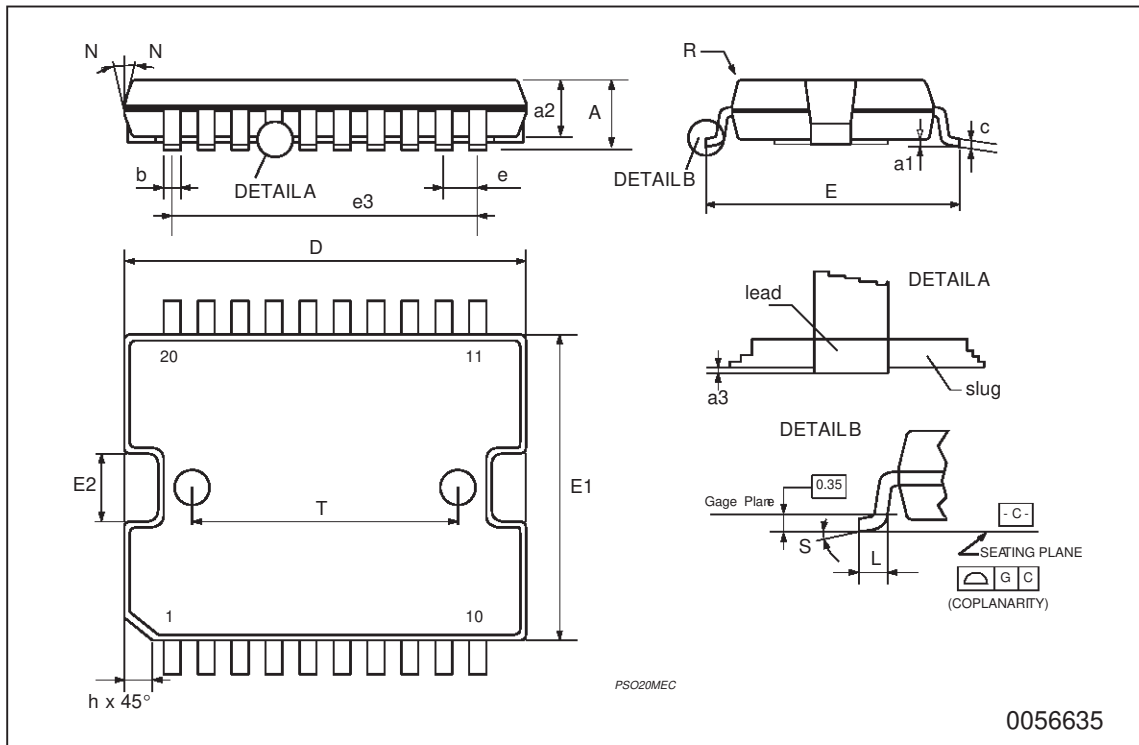



Information furnished is believed to be accurate and reliable. However, SGS-THOMSON Microelectronics assumes no responsibility for the consequences of use of such information nor for any infringement of patents or other rights of third parties which may result from its use. No license is granted by implication or otherwise under any patent or patent rights of SGS-THOMSON Microelectronics. Specifications mentioned in this publication are subject to change without notice. This publication supersedes and replaces all information previously supplied. SGS-THOMSON Microelectronics products are not authorized for use as critical components in life support devices or systems without express written approval of SGS-THOMSON Microelectronics.

© 1998 SGS-THOMSON Microelectronics - Printed in Italy - All Rights Reserved

SGS-THOMSON Microelectronics GROUP OF COMPANIES  
Australia - Brazil - Canada - China - France - Germany - Italy - Japan - Korea - Malaysia - Malta - Morocco - The Netherlands -  
Singapore - Spain - Sweden - Switzerland - Taiwan - Thailand - United Kingdom - U.S.A



...