

GENERAL DESCRIPTION

The OB3372 is a high power dual output LED driver optimized for large size LED backlighting application. It integrates two independent boost converters, providing a high performance and high reliability LED backlighting solution.

It incorporates two boost converters operating in current mode PWM control at fixed frequency. The operation frequency is programmed from 100 kHz to 600 kHz by setting an external resistor at RT pin.

The OB3372 can be configured for Master-Slave operation to support multi-channel applications. The voltage across LED current sense resistor is regulated to about 600mV to reduce power loss and improve efficiency.

The external PWM dimming mode is supported. The PWM dimming signal is injected externally from DIM pin.

The OB3372 offers comprehensive protection such as power MOSFET over current protection (OCP), output over voltage protection (OVP), IC power supply under voltage lockout (UVLO), and LED open & short protection.

TYPICAL APPLICATION

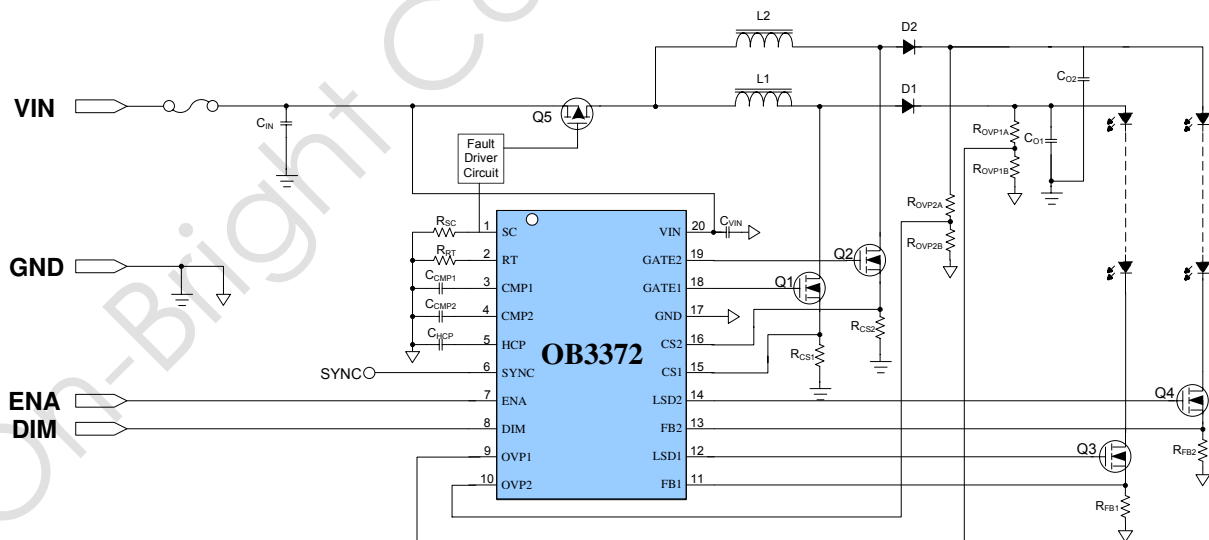

Figure1: OB3372 Typical Application Schematic

FEATURES

- High Power Dual Output PWM Control
- 8V to 35V Input Voltage Range
- Master/Slave Synchronization Capability
- Programmable 100kHz~600kHz Operation Frequency
- Programmable Slope Compensation
- External PWM Dimming Mode
- Over Voltage Protection
- Over Current Protection
- Under Voltage Lockout (UVLO)
- LED Open Protection
- LED Short Protection

APPLICATIONS

- LCD TV
- LCD Monitor
- Flat panel display

Absolute Maximum Ratings

Parameter	Value
Vin Input Voltage to GND	-0.3V to 40V
GATE / LSD to GND	-0.3V to 40V
I/O (except GATE/LSD) to GND	-0.3V to 7V
Operating Ambient Temp. T _A	-20°C ~ 85°C
Operating Junction Temp. T _J	-40 ~ 150°C
Min/Max Storage Temp. T _{stg}	-55 ~ 150°C
Lead Temp. (10 Sec)	260 °C

Note: Stresses beyond those listed under “absolute maximum ratings” may cause permanent damage to the device. These are stress ratings only, functional operation of the device at these or any other conditions beyond those indicated under “recommended operating conditions” is not implied. Exposure to absolute maximum-rated conditions for extended periods

may affect device reliability.

Recommended Operating Range

Parameter	Value
Vin Voltage	8V to 35V
Operating Frequency	100k~600k

Ordering Information

Part Number	Description
OB3372KP	SOP20, pb-free in tube
OB3372LP	SSOP20, pb-free in tube

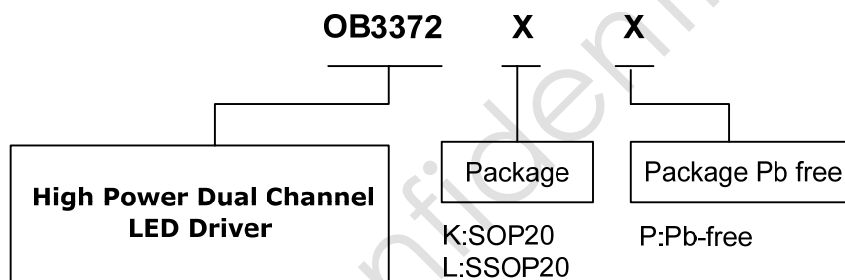

Marking Information

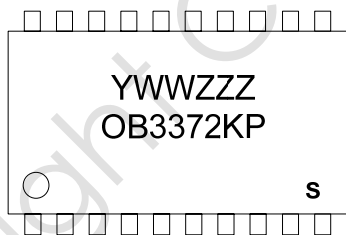

Y:Year Code
 WW:Week Code(01-52)
 ZZZ:Lot Code
 K:SOP20 Package
 P:Pb-free Package
 S:Internal Code(Optional)



Y:Year Code
 WW:Week Code(01-52)
 ZZZ:Lot Code
 L:SSOP20 Package
 P:Pb-free Package
 S:Internal Code(Optional)

Pin Configuration for OB3372KP/LP

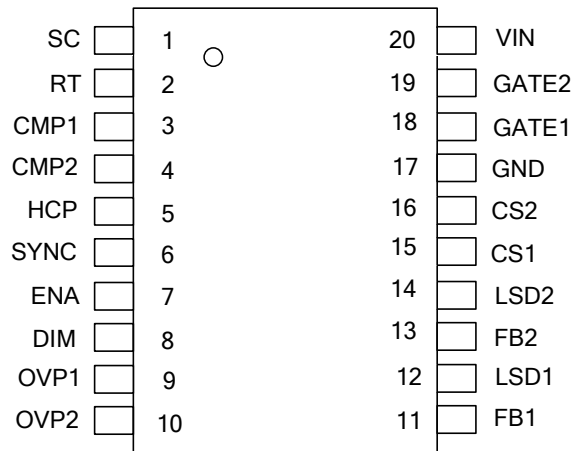

Terminal Assignment for OB3372KP/LP

Number	Pin Name	I/O	Pin Function
1	SC	Output	Connect an external resistor to GND for slope compensation setup This pin is pulled to 5V when there is an output short circuit condition or DC/DC loop disconnection condition
2	RT	I/O	Connect an external resistor to GND to set master operation mode and to set boost converter switching frequency Connect an external capacitor to GND to set slave operation mode and to set internal PLL loop compensation
3	CMP1	I/O	Loop compensation for channel1
4	CMP2	I/O	Loop compensation for channel2
5	HCP	I/O	Hiccup timer setting
6	OVP1	Input	Output over voltage protection sense for channel 1
7	OVP2	Input	Output over voltage protection sense for channel 2
8	SYNC	I/O	Input/output signal for operation frequency synchronization
9	ENA	Input	Chip enable control
10	DIM	Input	External PWM dimming control
11	FB1	Input	LED current feedback input for channel1
12	LSD1	Output	This pin is used to drive an external MOSFET which disconnects the load from the circuit during a fault condition or during PWM dimming for channel1
13	FB2	Input	LED current feedback input for channel2
14	LSD2	Output	This pin is used to drive an external MOSFET which disconnects the load from the circuit during a fault condition or during PWM dimming for channel2
15	CS1	Input	Current sense input for GATE1
16	CS2	Input	Current sense input for GATE2

Number	Pin Name	I/O	Pin Function
17	GND	Ground	Power ground
18	GATE1	Output	Gate drive output for channel1
19	GATE2	Output	Gate drive output for channel2
20	VIN	Power	Power supply

Functional Block Diagram

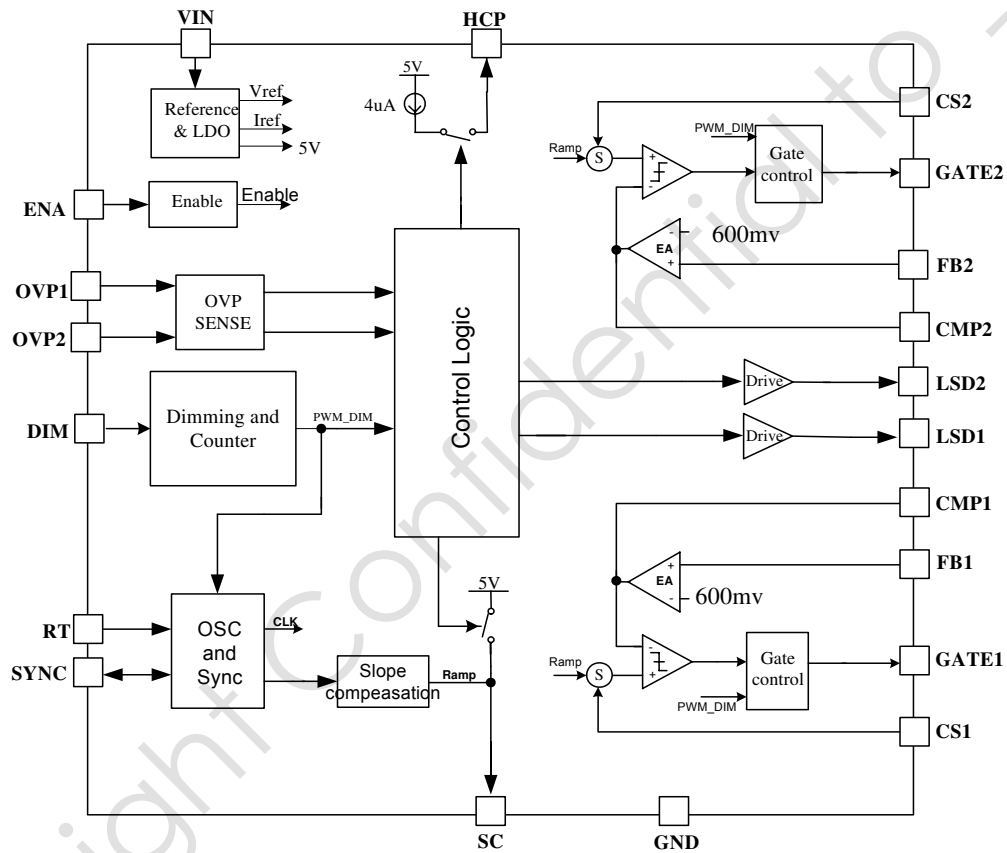

Figure2: OB3372 Functional Block Diagram

Electrical Characteristics

VIN=12V, ENA=5V, RT=20k ohm to ground, TA=25°C, if not otherwise noted.

Parameter	Symbol	Test Conditions	Min	Tyc	Max	Unit
Supply Voltage						
Operating Input Voltage	VIN		8		35	V
Supply Current (Quiescent)	I _{VIN-op}	Vin=12V, DIM=5V, no load		3	5	mA
Supply Current (Disable)	I _{VIN-disable}	8V<Vin<35V, ENA=0V, disable mode, no load		4	10	uA
UVLO(OFF)	UVLO_off	Rising edge		6.8		V
UVLO (ON)	UVLO_on			6.5		V
ENA ON Threshold	ENA_on	ENA rising	2.8			V
ENA OFF Threshold	ENA_off	ENA falling			1	V
ENA pull down resistor	R _{ENA}			100		kΩ
RT Voltage	V _{RT}			1.2		V
Oscillator						
Operation Frequency	Fop	RT=60k		100		kHz
Operation Frequency	Fop	RT=10k		600		kHz
SYNC input high voltage	V _{SYNC-H}		1.6			V
SYNC input low voltage	V _{SYNC-L}				1.2	V
SYNC rising time	T _{r_sync}	Csync=1nF, 10%-90%		350		ns
SYNC falling time	T _{f_sync}	Csync=1nF, 10%-90%		250		ns
PWM Control						
Feedback voltage for FB	VFB		570	600	630	mV
Lead edge blanking time	T _{LEB}			250		ns
Maximum Duty Cycle	Duty _{max}		85	90	95	%
Slope rate of soft start	SR _{SS}			13		V/s
Error Amplifier						
Input common-mode range	VCM		0		3.5	V
Output voltage range	Vo		1		4	V
Transconductance	Gm			100		uA/V
Maximum Output Current	I _{comp}			65		uA
PWM Dimming						
DIM High Threshold	Vpwmi_h			2		V
DIM Low Threshold	Vpwmi_l			1.8		V
Gate drive						
Clamp of GATE output	Vclamp_gate			11		V
GATE rising time	Ts	CGATE=2nF, 10%-90%		80		ns
GATE falling time	Tf	CGATE=2nF, 10%-90%		40		ns
Protection						
OVP Over Voltage Threshold	Vovp_ov	Rising edge		2		V
FAULT protection threshold	V _{th_fault}			100		mV
Blanking time of LED fault detection	T _{blanking_FB}			500		ns

Symbol	Parameter	Test Conditions	Min	Tyc	Max	Unit
Protection						
VOUT short protection threshold	$V_{th_voshort}$			150		mV
LED open protection threshold	V_{th_open}			200		mV
LED short protection threshold	V_{th_short}			1		V
Charging current for HCP	I_{HCP}	FB>1V		4		uA
Frequency of HCP	f_{HCP}	HCP=1nf		2		kHz
Voltage swing for hiccup time	ΔV_{HCP}			2		V
Clamp of LSD output	V_{clamp_LSD}			11		V
LSD rising time	T_s	Clsd=330pF, 10%--90%		330		ns
LSD falling time	T_f	Clsd=330pF, 10%--90%		180		ns

Function Description

General Operation

The OB3372 is a dual channel LED driver designed for boost DC-DC converters in a fixed frequency mode. The controller implements a peak current mode control (with programmable slope compensation) and an internal transconductance amplifier to accurately control the output current over a wide input and load conditions. Furthermore, in more than 2 LED string applications, multiple OB3372 chips can be synchronized to the master OB3372 (the master OB3372 has a resistor connected to its RT pin; the slave OB3372 has a capacitor connected to its RT pin) or to an external clock through the SYNC pin. The IC also provides a gate drive output to control an external disconnect MOSFET switch that disconnect the LEDs in case of a fault condition or dimming off state.

Low frequency PWM dimming input that can accept an external control signal with a duty ratio of 0-100% and a frequency of up to a few tens of kilohertz.

OB3372 offers comprehensive protection features to protect the system in various fault conditions such as output over voltage protection, boost diode disconnection protection and output short circuit protection. The open/short LED string protection ensures that failure of one or two LED strings does not result in whole LED array out of function. The cycle-by-cycle current limit function limits the maximum current flowing through the external power MOSFET,

Startup

OB3372 is enabled by applying a voltage of greater than approximately 2.8V to ENA pin. An on-chip internal 100k ohm pull down resistor is placed between ENA pin and ground. The ENA signal has the highest priority in the control of the IC. OB3372 supports a low power feature of less than 10uA current consumption in standby mode (ENA=0). A voltage of less than approximately 1V will disable the controller.

Once OB3372 is enabled the internal 5V regulator will be activated to supply the whole chip.

UVLO

An under-voltage lockout protection feature with a hysteresis of about 300mv is provided for VIN. When the voltage at this pin exceeds a threshold of approximately 6.8V, the IC starts the normal operation. If the voltage at this pin drops below a threshold of approximately 6.5V, it stops switching

operation. The switching operation is resumed when the voltage at pin VIN recovers to a voltage above 6.8V.

LED Current Regulation

The LED currents are sensed by current sense resistors connected to pins FB1 and FB2 respectively. The sensed current signal is compared with a pre-defined reference level (600mv) and the error signal is amplified as the control signal. It is compared with the CS pin sensing current signal plus the slope compensation to determine the on-time of the switching MOSFET. The error amplifier sources or sinks the current to the COMP pin to adjust the required inductor current as the load changes. The slope-compensation signal is added to the current-sense signal to improve the stability at high duty cycles in CCM mode.

At light loading, the OB3372 automatically skips some pulses to improve efficiency and prevent overcharging the output capacitor. In this pulse-skipping mode, the inductor current ramps up for a minimum on-time (typical 250ns), then deliver the stored energy to the output. The switch remains off until another pulse is needed to boost the output voltage.

The LED current is approximated by the following equation;

$$I_{LED} [mA] = \frac{600[mV]}{R_{FB} [\Omega]}$$

Slope Compensation

The fixed frequency, Peak Current-Mode topology has the advantage of fast transient response and very easy loop compensation with ceramic output capacitors. In addition, the intrinsic peak-current measurement simplifies the current limit protection, avoiding undesired saturation of the inductor.

On the other side, it has a drawback: there is inherent loop instability when operating with duty-cycle greater than 50%. The stability can be improved by slope compensation. In *Figure 3*, where the switching duty-cycle is greater than 50%, the small perturbation ΔI_L dies away in subsequent cycles thanks to the slope compensation and the system reverts to a stable situation.

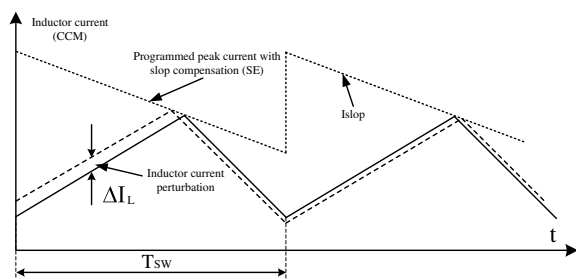

Figure 3 Effect of slope compensation

The SC pin allows to properly set the amount of slope compensation by connecting a simple resistor R_{SC} between the SC pin and ground. The compensation ramp starts at 0 % (typ.) of each switching period and its slope is given by the following equation:

$$S_E = \frac{K_{slop}}{R_{RT} \cdot R_{SC}} [A/s]$$

Where $K_{slop} = 1.33 \times 10^{10} V \cdot \Omega/s$ and S_E is the slope ramp in [A/s].

To avoid sub-harmonic instability, the compensating slope should be at least half of the slope of the inductor current S_L during the off-phase for a duty-cycle greater than 50 % (i.e. at the lowest input voltage).

$$S_L = \frac{R_{CS} \times (V_{out} - V_{in})}{14000 \cdot L} [A/s]$$

The value of R_{SC} can be calculated according to the following equation.

$$R_{SC} \leq \frac{3.724 \times 10^{14} \cdot L}{(V_{out} - V_{in}) \cdot R_{RT} \cdot R_{CS}} [\Omega]$$

Multi controller synchronization

Multiple controller application is supported by OB3372. More than two LED strings are synchronized in Master-Slave or Slave-Slave mode.

Master mode can be set by connecting an external resistor from pin RT to GND. In master mode, SYNC pin will output a clock pulse whose frequency is determined by RT resistor value.

Slave mode can be set by connecting a capacitor (typical 4.7nF) from pin RT to GND. In slave mode, the SYNC pin will be used as input pin receiving a TTL compatible pulse signal.

As shown in figure 4, one OB3372 is configured in master mode and the other one operates in slave mode. More than two OB3372 can be configured in slave mode.

As shown in figure 5, all OB3372s can be configured in slave mode when an external clock source is used as input SYNC signal.

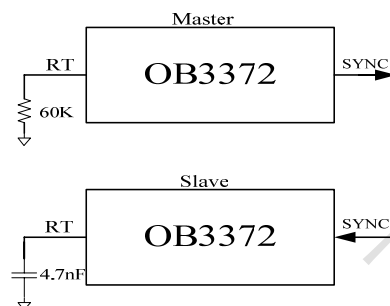

Figure 4 Master and slave mode

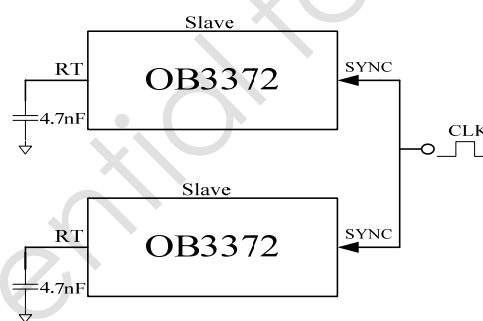

Figure 5 Slave and slave mode

Frequency Selection

The switching frequency is set by the resistor value in master mode. The operating frequency can be approximated by the following equation:

$$f_{op} [KHz] = \frac{6000}{R_{RT} [K\Omega]}$$

In slave mode, this frequency is set by input CLK frequency from SYNC pin.

High frequency operation optimizes the regulator for small component size at the expense of efficiency due to increased switching losses. While low frequency operation offers the better overall efficiency, but requires larger components and more PCB area.

Dimming Control

The LED brightness is controlled by the PWM signal at DIM pin which has different duty cycle. OB3372 can accept an external PWM signal to DIM pin in the range of 100Hz to 20KHz with a swing voltage of 0V to a level greater than 2V.

Both channels share the same dimming control. When the voltage at pin DIM exceeds a threshold of approximately 2V, the LED strings are turned on. And when the voltage at pin DIM is lower than approximately 1.8V, the LED strings are turned off.

OVP Protection

An output over-voltage condition for each channel is monitored independently by the voltage at pins OVP1 and OVP2. During normal operation, when the voltage at either pin, OVP1 or OVP2, exceeds a threshold of approximately 2.0V, the over-voltage protection function is activated and the corresponding channel is turned off immediately. This protection state can be recovered once OVP voltage falls between 0.15V and 1.8V.

VOUT SHORT Protection

VOUT short condition for each channel is monitored independently by the voltage at pins OVP1 and OVP2. During normal operation, when the voltage at either pin, OVP1 or OVP2, drops below a threshold of approximately 0.15V, the VOUT-short protection function is activated and the GATE and LSD drive is turned off.

This state is latched and only toggling ENA can resume operation.

FAULT State Protection

After OB3372 is enabled, it will first check the voltage at pins OVP1 and OVP2. A delay time of about 1ms is added before this action in order to avoiding false settling of these voltages. When the voltage at either pin, OVP1 or OVP2, is below a threshold of approximately 0.1V, the FAULT protection function is activated and the IC will be shut down.

This state is latched and only toggling ENA can resume operation.

LED String Open Protection

LED string open protection condition for each channel is monitored independently by the voltage at pins OVP1, OVP2, FB1 and FB2. When LED string is open, FB voltage will go low and as a result OVP voltage will go high. During normal operation, when the voltage at pin FB1/FB2, drops below a threshold of approximately 0.2V and the voltage at pin OVP1/OVP2 exceeds a threshold of approximately 2.0V, a LED open flag will be generated. Once LED open protection is activated LSD and GATE output will be turned off. Toggling ENA can resume operation.

LED String Short Protection

LED string short protection condition for each channel is monitored independently by the voltage at pins FB1 and FB2. When LED string is short, FB voltage will go high. During normal operation, when the voltage at pin FB1/FB2 exceeds a threshold of approximately 1V, a LED short flag will be generated. Once LED short protection is activated LSD and GATE pin will be turned off. This state will be latched.

After LED short flag is generated, the capacitor at pin HCP is charged by a current of about 4uA and thus the IC enters Hiccup mode. Once the voltage at pin HCP exceeds a threshold of approximately 2V, the LED short state will be reset and the CMP pin are released and GATE and LSD pins are allowed to turn on. Then, OB3372 will go into a soft-start mode ensuring a smooth recovery for the LED current. The value of the capacitor required for a given hiccup time is given by:

$$C_{HCP} = \frac{4\mu A * T_{HCP}}{2V}$$

Package Mechanical Data: SOP20

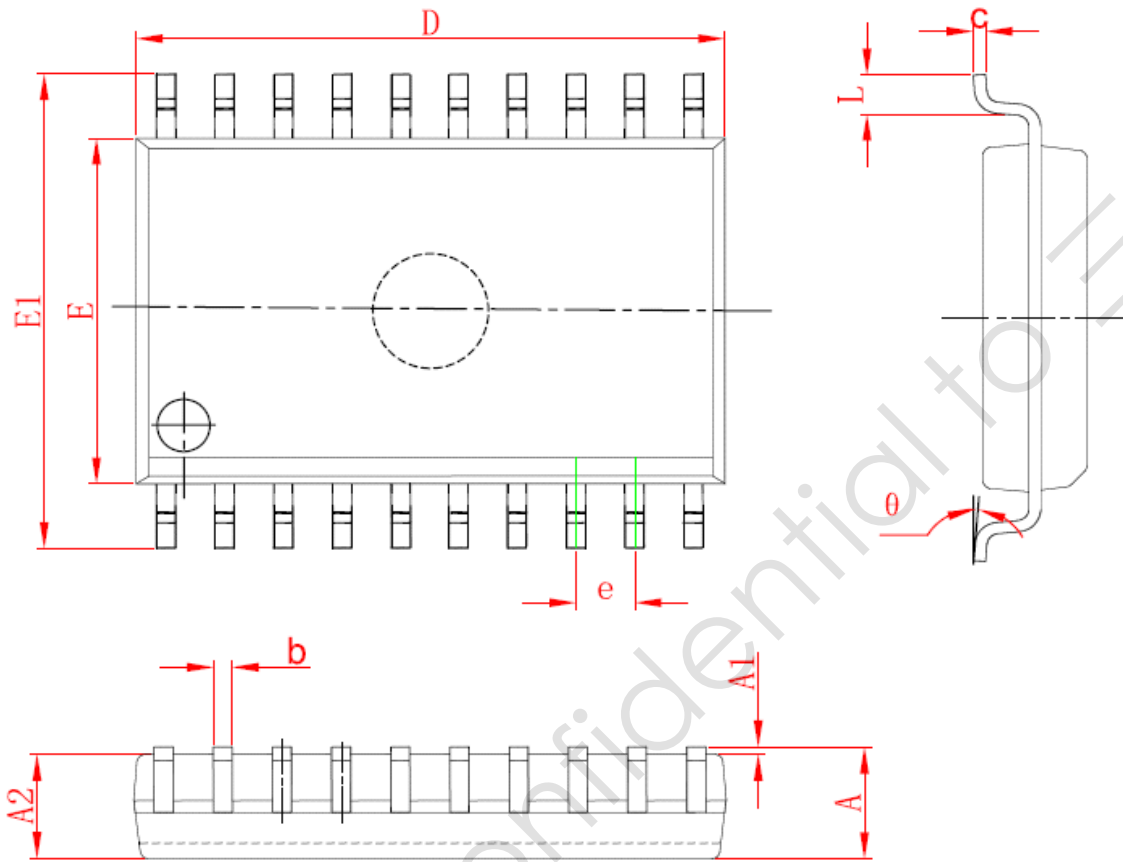

Symbol	Dimensions In Millimeters		Dimensions In Inches	
	Min	Max	Min	Max
A	2.350	2.650	0.093	0.104
A1	0.100	0.300	0.004	0.012
A2	2.050	2.550	0.081	0.100
b	0.310	0.510	0.012	0.020
c	0.200	0.330	0.008	0.013
D	12.520	13.000	0.493	0.512
E	7.400	7.600	0.291	0.299
E1	10.000	10.610	0.394	0.418
e	1.27 (BSC)		0.05 (BSC)	
L	0.400	1.270	0.016	0.050
θ	0°	8°	0°	8°

Package Mechanical Data: SSOP20

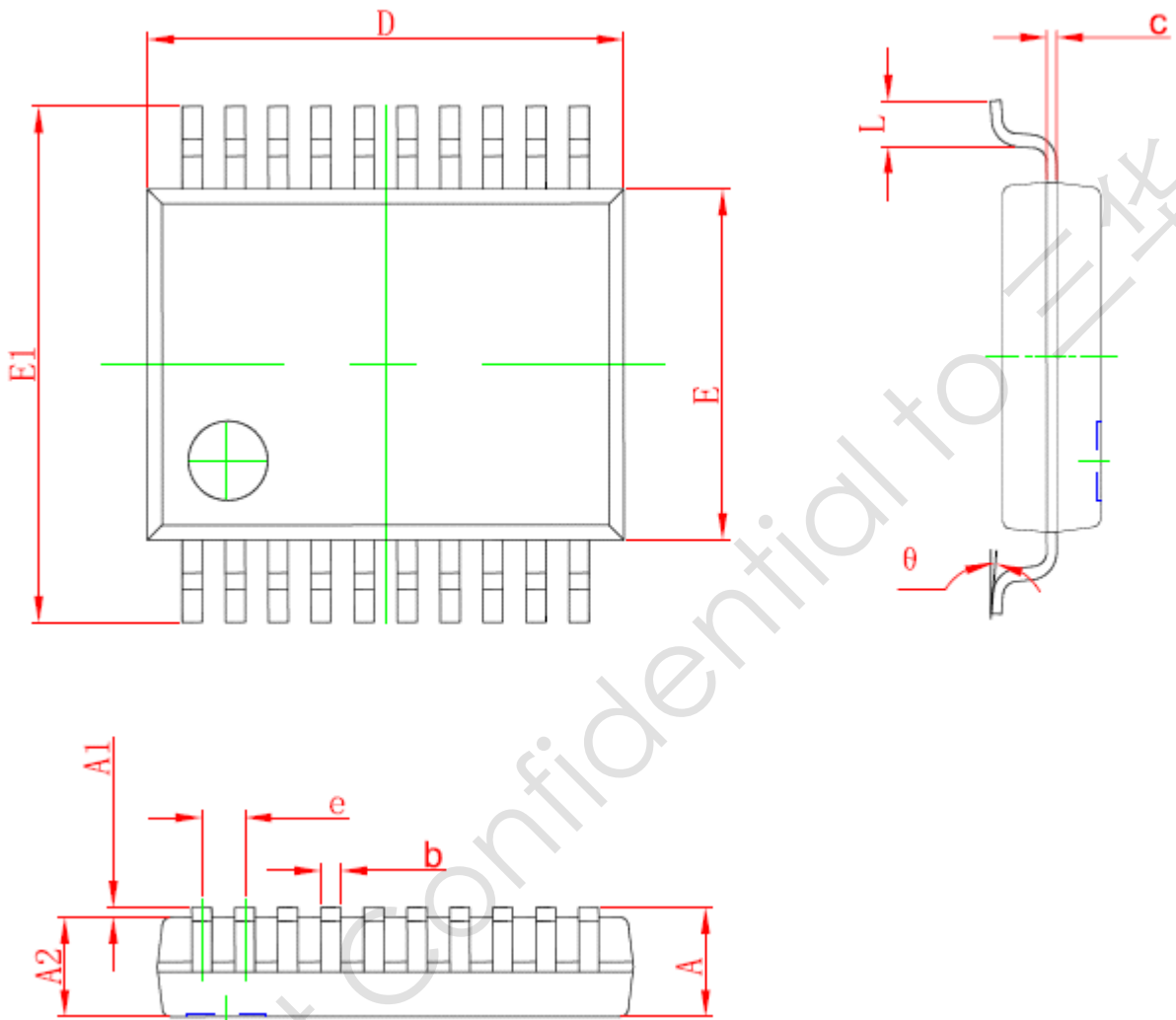

Symbol	Dimensions In Millimeters		Dimensions In Inches	
	Min	Max	Min	Max
A	-	1.75	-	0.069
A1	0.10	0.25	0.004	0.010
A2	1.25	-	0.049	-
b	0.21	0.31	0.008	0.012
c	0.10	0.25	0.004	0.010
D	8.53	8.73	0.336	0.344
E	3.80	4.00	0.150	0.158
E1	5.80	6.20	0.232	0.248
e	0.535	0.735	0.021	0.029
L	0.400	1.270	0.016	0.050
θ	0°	8°	0°	8°

Important Notice

Right to make changes

On-Bright Electronics Corp. reserves the right to make corrections, modifications, enhancements, improvements, and other changes to its products and services at any time and to discontinue any product or service without notice. Customers should obtain the latest relevant information before placing orders and should verify that such information is current and complete.

Warranty information

On-Bright Electronics Corp. warrants performance of its hardware products to the specifications applicable at the time of sale in accordance with its standard warranty. Testing and other quality control techniques are used to the extent it deems necessary to support this warranty. Except where mandated by government requirements, testing of all parameters of each product is not necessarily performed.

On-Bright Electronics Corp. assumes no liability for applications assistance or customer product design. Customers are responsible for their products and applications using On-Bright's components, data sheet and application notes. To minimize the risks associated with customer products and applications, customers should provide adequate design and operating safeguards.

Life support

On-Bright Electronics Corp.'s products are not designed to be used as components in devices intended to support or sustain human life. On-bright Electronics Corp. will not be held liable for any damages or claims resulting from the use of its products in medical applications.

Military

On-Bright Electronics Corp.'s products are not designed for use in military applications. On-Bright Electronics Corp. will not be held liable for any damages or claims resulting from the use of its products in military applications.