

Overview

Bipolar IC

Features

- Integrated free-wheeling diodes
- Outputs short-circuit proof to V_S and ground
- Thermal overload protection
- Blocking of the output stages upon undervoltage
- Final push-pull stage free of cross-over

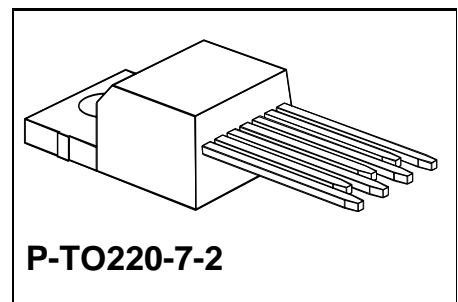
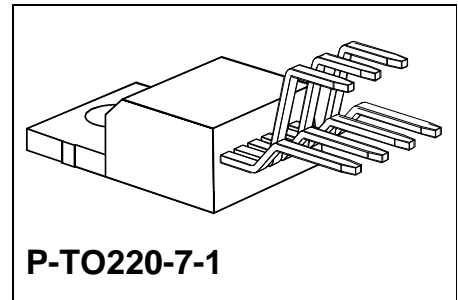

Type	Ordering Code	Package
TLE 4203	Q67000-A8121	P-TO220-7-1
TLE 4203 S	Q67000-A9101	P-TO220-7-2

Description

The integrated circuit TLE 4203 is a versatile double power driver of up to 4 A output current which is particularly suitable as a driver for DC motors in reversible operation.

The push-pull power output stages operate in the switching mode and can be combined to a full-bridge configuration.

The drive of the input stage is implemented using digital logic.

The device contains a temperature protection logic, output stages protected against short-circuit and integrated free-wheeling diodes.

Typical applications are for follow-up control, servo drives, servo motors, drive mechanisms, etc.

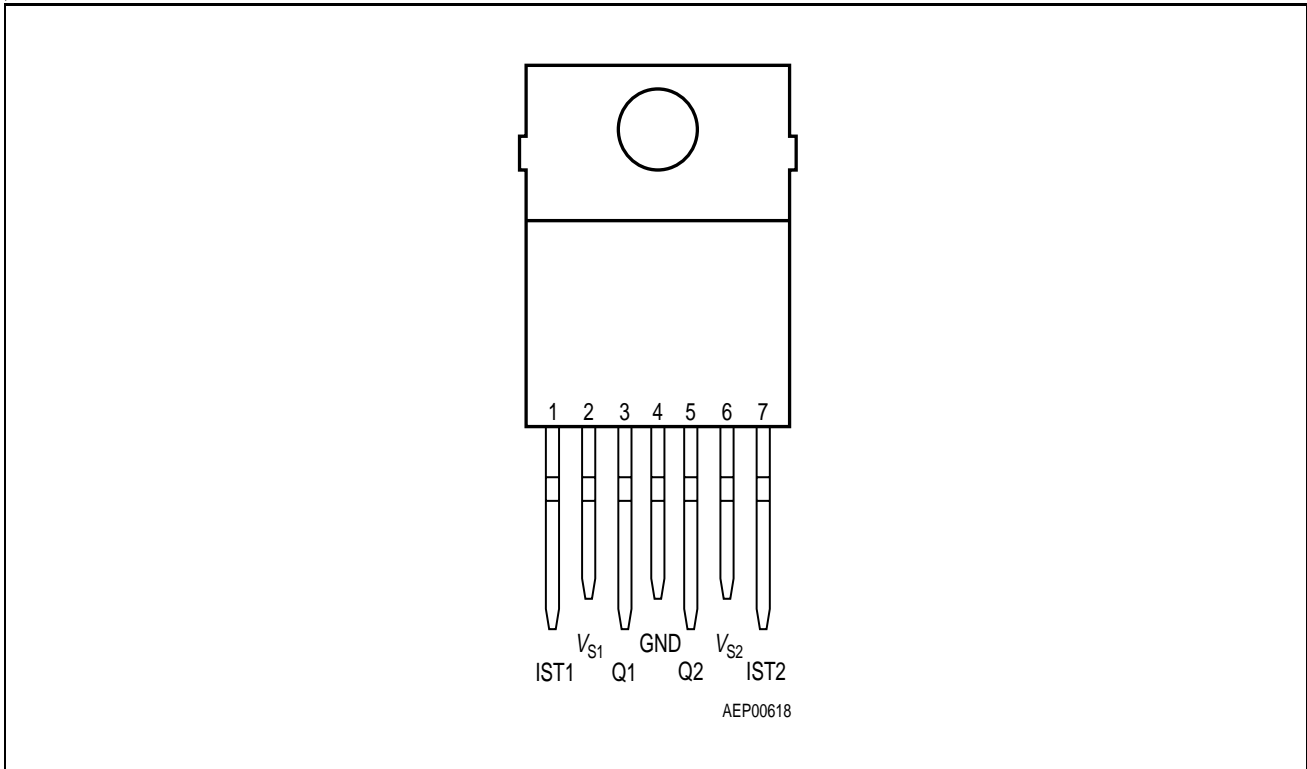

Figure 1 Pin Configuration (top view)

Pin Definition and Functions

Pin No.	Symbol	Function
1	IST1	Control input for channel 1 (TTL/CMOS-compatible), of non-inverting effect on the channel output.
2	V_{S1}	Channel 1 supply voltage ; externally connected with the supply voltage pin for channel 2 (pin 6).
3	Q1	Short-circuit protected push-pull C output channel 1 for currents up to 6 A. Free-wheeling diodes are integrated on chip for inductive loads.
4	GND 1, 2	Ground ; track should be designed for the max. short-circuit current (2 x 6 A).
5	Q2	Short-circuit protected push-pull C output channel 2 for currents up to 6 A. Free-wheeling diodes are integrated on chip for inductive loads.
6	V_{S2}	Channel 2 supply voltage ; externally connected with the supply voltage pin for channel 1 (pin 2).
7	IST2	Control input for channel 2 (TTL/CMOS-compatible), of non-inverting effect on the channel output.

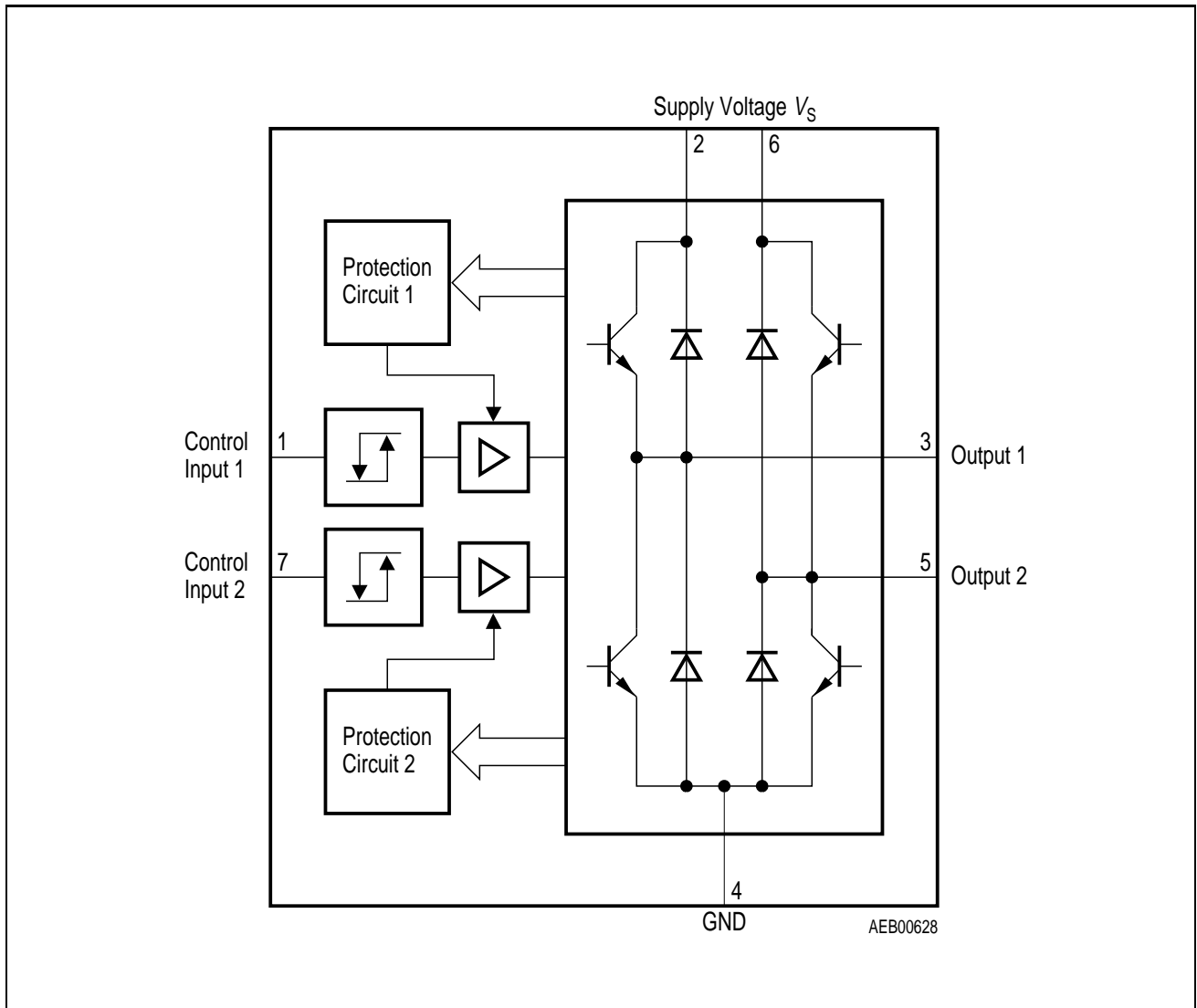

Figure 2 Block Diagram

Application

In industrial and automotive electronics, power full-bridge DC motor drivers are mostly used for bidirectional motor drives. The two TTL and CMOS-compatible control inputs act on the output as follows:

Status	Input 1	Input 2	Output 1	Output 2
1	L	L	V_{QL}	V_{QL}
2	L	H	V_{QL}	V_{QH}
3	H	L	V_{QH}	V_{QL}
4	H	H	V_{QH}	V_{QH}

V_{QL} means: Lower power unit conducting; upper power unit blocked.

V_{QH} means: Upper power unit conducting; lower power unit blocked.

The following examples illustrate the operation:

Status 1: Motor is slowed down

Status 2: Motor turns right

Status 3: Motor turns left

Status 4: Motor is slowed down

Circuit Description

Input Circuit

The control inputs consist of TTL and CMOS-compatible Schmitt triggers with hysteresis. Buffer amplifiers, controlled from these stages, convert the logic signal into the form required for driving the power output stages.

Output Stages

The output stages consist of two push-pull C stages. Using protective circuits for limiting the power dissipation makes the outputs short-circuit proof to ground and to supply voltage throughout the entire operating range. Positive and negative voltage peaks, which occur when switching inductive loads, are limited by integrated power diodes.

Monitoring and Protecting Functions

The IC is protected against thermal overloads by a temperature protecting circuit.

In addition an internal circuit ensures that all output transistors are blocked for supply voltages below operating range.

A monitoring stage logic for each output stage transistor detects whether the relevant transistor is active and in this case for sink operation (source operation) prevents the corresponding source transistor (sink transistor) from being turned on. Direct cross-over currents are effectively prevented with this method.

Absolute Maximum Ratings

$T_C = -40$ to 125 °C

Parameter	Symbol	Limit Values		Unit
		min.	max.	

Voltages

Supply voltage	V_S	- 0.3	45	V
Logic input voltages	$V_{I1,2}$	- 45	45	V

Currents

Supply current $T_C \leq 85$ °C	I_S	- 12	12	A
Output current $T_C \leq 85$ °C	$I_{Q1,2}$	- 6	6	A
Ground current $T_C \leq 85$ °C	I_{GND}	- 12	12	A

Temperatures

Junction temperature	T_j	-	150	°C
Storage temperature range	T_{stg}	- 50	150	°C
Thermal resistances				
system - case	$R_{th SC}$	-	3	K/W
system - ambient	$R_{th SA}$	-	65	K/W

Operating Range

Supply voltage	V_S	5	20	V
Logic input voltage	$V_{I1,2}$	- 10	40	V
Case temperature $T_j \leq 150$ °C	T_C	- 40	125	°C

Characteristics

$V_S = 8$ to 18 V, $T_j = -25$ to 125 °C (typ. $V_S = 12$ V; $T_j = 25$ °C)

Parameter	Symbol	Limit Values			Unit	Test Condition
		min.	typ.	max.		

General Characteristics

Quiescent current	I_q	–	70	100	mA	$V_{I1} = V_{I2} > V_{IH}$
Quiescent current	I_q	–	180	230	mA	$V_{I1} = V_{I2} < V_{IL}$

Logic

Control inputs						
H-input voltage	V_{IH}	2.8	–	–	V	–
L-input voltage	V_{IL}	–	–	1.2	V	–
Hysteresis of input voltage	ΔV_i	–	0.7	–	V	–
H-input current	I_{IH}	–	–	10	μ A	$V_i = 5$ V
L-input current	$-I_{IL}$	–	–	10	μ A	$V_i = 0.5$ V

$V_S = 8$ to 18 V, $T_C = -25$ to 125 °C

Switching Stages

Saturation voltages to + V_S	V_{QSato}	–	1.1	1.3	V	$V_{I1,2} > V_{IH}; I_Q = -1$ A ¹⁾
to + V_S	V_{QSato}	–	1.5	1.8	V	$V_{I1,2} > V_{IH}; I_Q = -2$ A ¹⁾
to + V_S	V_{QSato}	–	2.5	3.5	V	$V_{I1,2} > V_{IH}; I_Q = -4$ A ¹⁾
to ground	V_{QSatu}	–	0.3	0.6	V	$V_{I1,2} < V_{IL}; I_Q = 1$ A
to ground	V_{QSatu}	–	0.6	1	V	$V_{I1,2} < V_{IL}; I_Q = 2$ A
to ground	V_{QSatu}	–	1.6	3.2	V	$V_{I1,2} < V_{IL}; I_Q = 4$ A

Forward Voltages

Diode to + V_S	$-V_{QFo}$	–	0.95	1.3	V	$V_{I1/2} > V_{IH}; I_Q = 1$ A ¹⁾
Diode to + V_S	$-V_{QFo}$	–	1.05	1.5	V	$V_{I1/2} > V_{IH}; I_Q = 2$ A ¹⁾
Diode of + V_S	$-V_{QFo}$	–	1.30	1.8	V	$V_{I1/2} > V_{IH}; I_Q = 4$ A ¹⁾
Diode to ground	$-V_{QFu}$	–	0.95	1.3	V	$V_{I1/2} < V_{IL}; I_Q = -1$ A
Diode to ground	$-V_{QFu}$	–	1	1.5	V	$V_{I1/2} < V_{IL}; I_Q = -2$ A
Diode to ground	$-V_{QFu}$	–	1.20	1.8	V	$V_{I1/2} < V_{IL}; I_Q = -4$ A

¹⁾ measured to + V_S

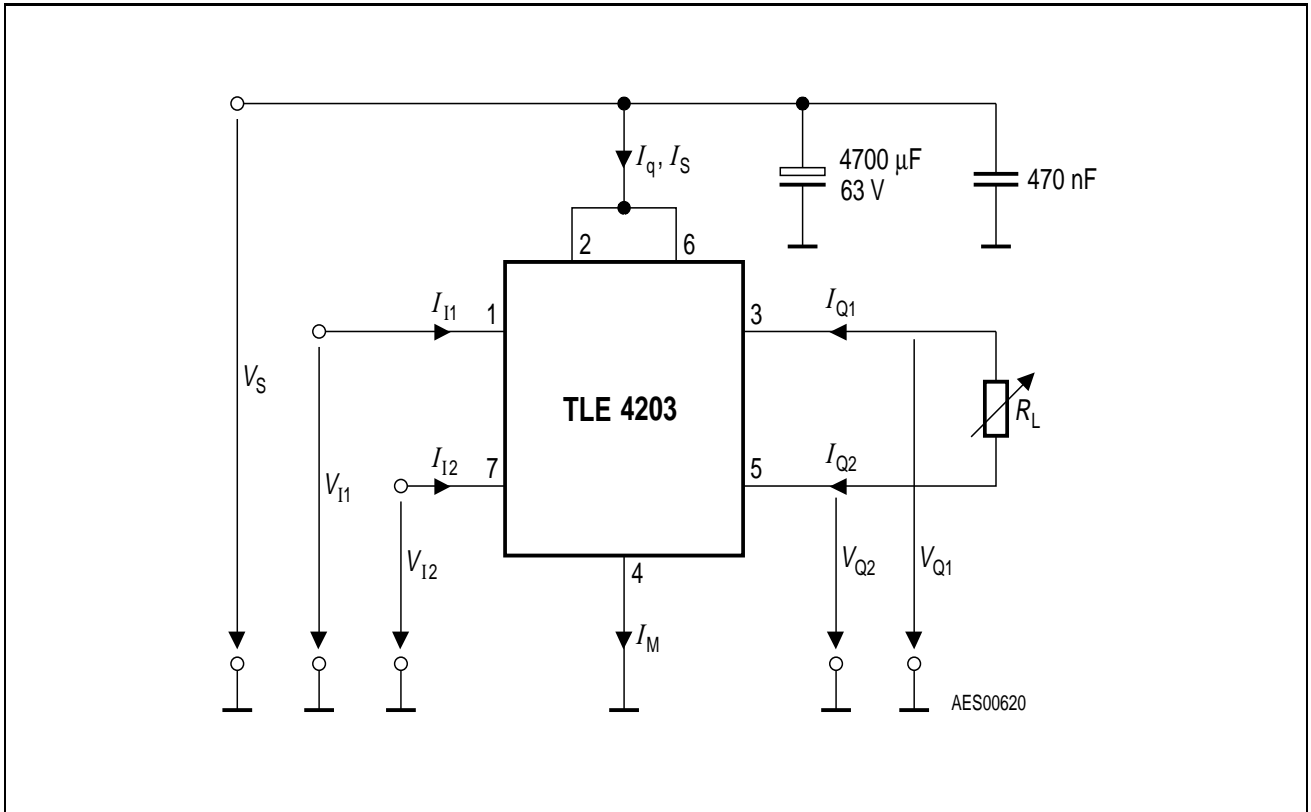

Figure 3 Test Circuit

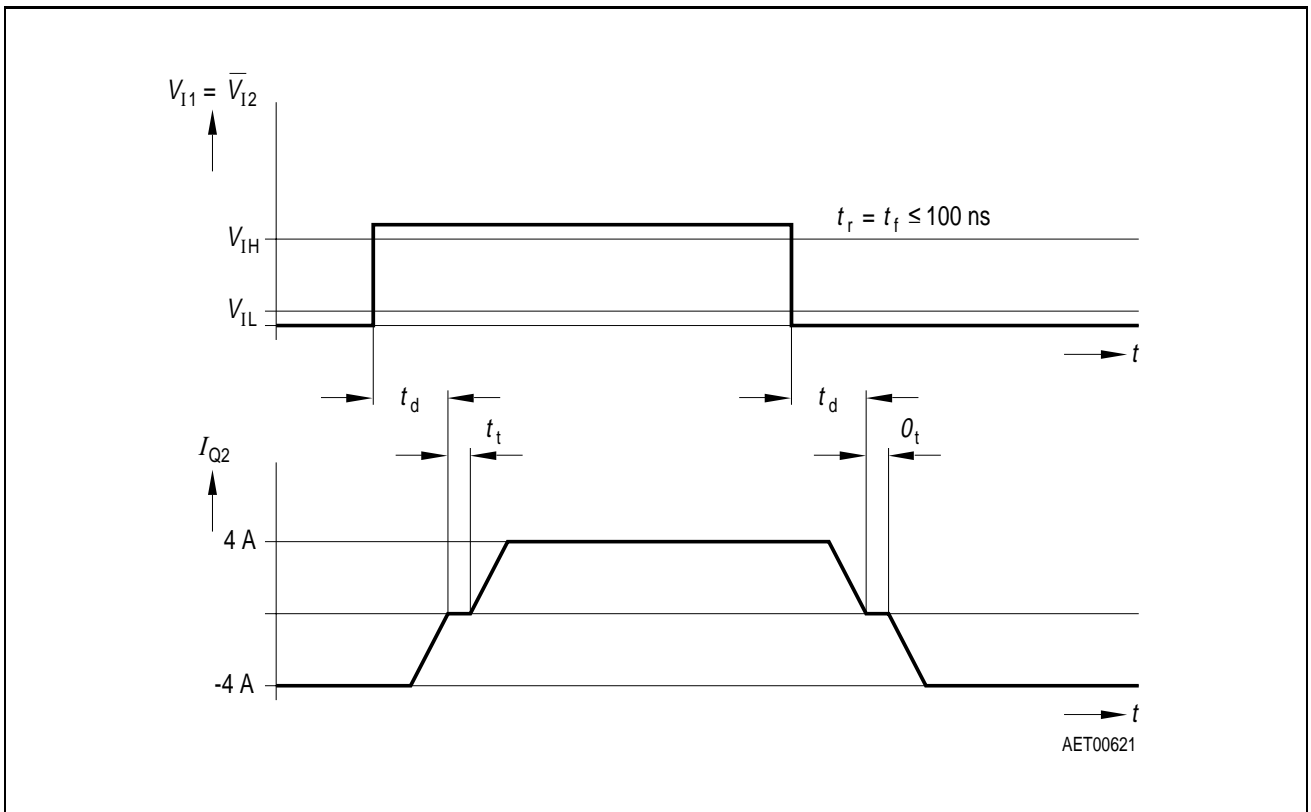

Figure 4 Timing Diagram

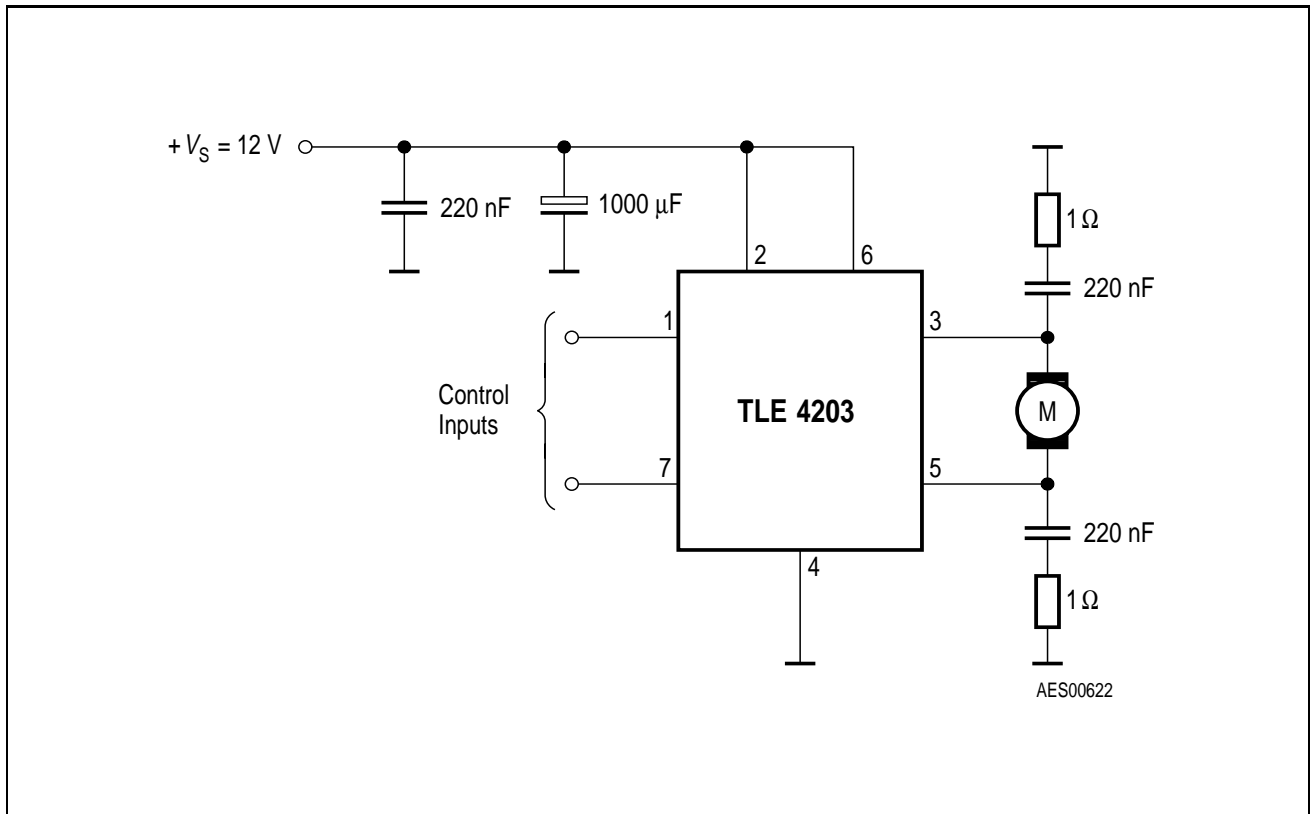
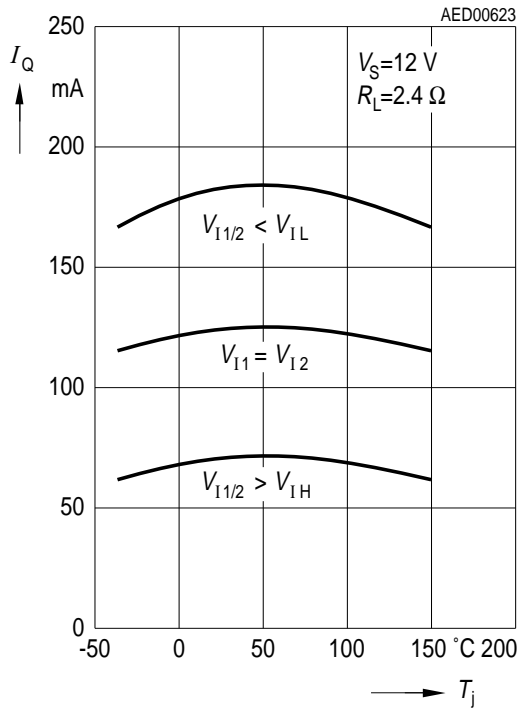

Figure 5 Application Circuit

Saturation Voltage versus Output Current



Short-Circuit Current versus Output Voltage

$V_A = V_Q$ for sink operation
 $V_A = V_S - V_Q$ for source operation

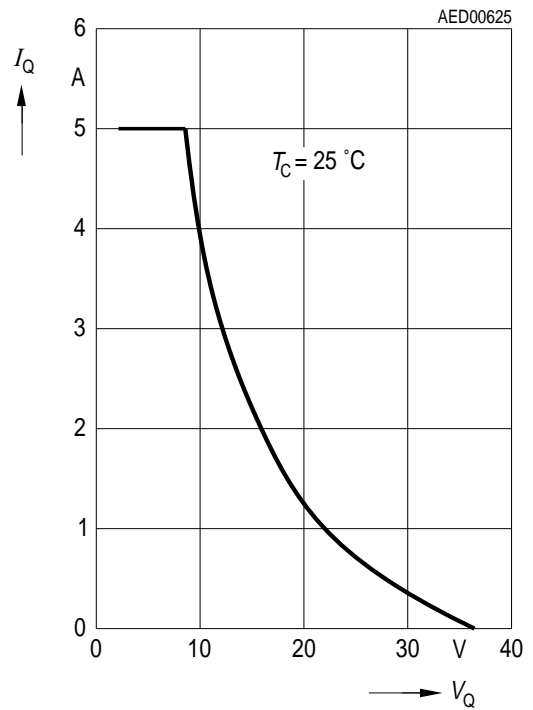

Saturation Voltage versus Output Current

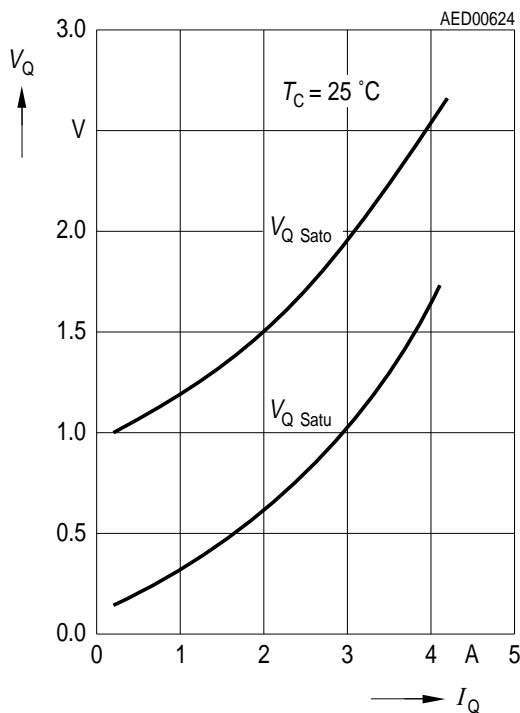

Diode Forward Voltage versus Output Current

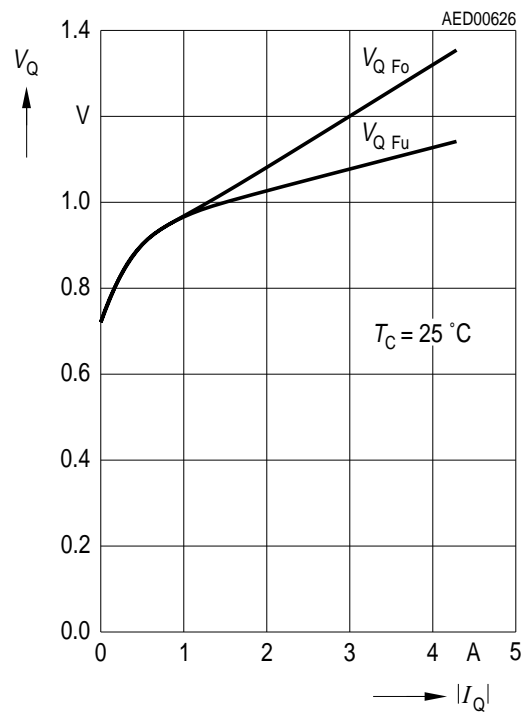

Package Outlines

P-TO220-7-1

(Plastic Transistor Single Outline)

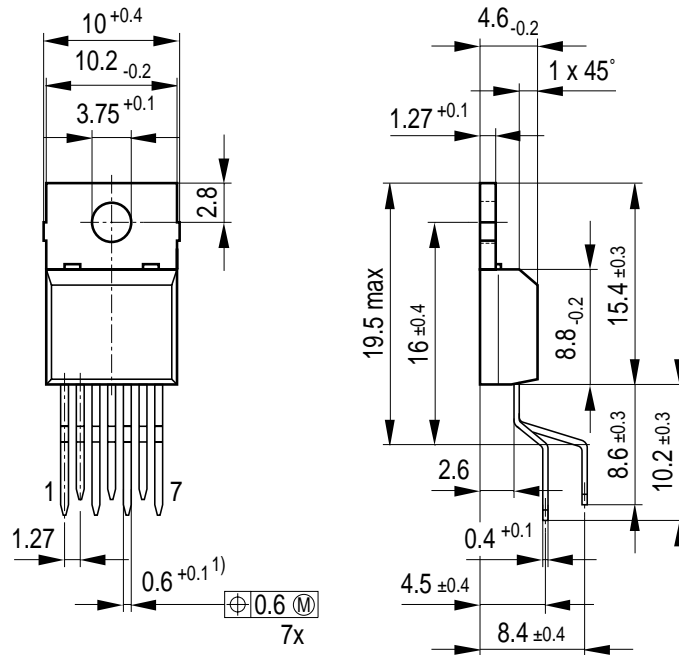

1) $0.75^{-0.15}$ at dam bar (max 1.8 from body)

1) $0.75^{-0.15}$ im Dichtstegbereich (max 1.8 vom Körper)

GPT05108

Sorts of Packing

Package outlines for tubes, trays etc. are contained in our Data Book "Package Information".

Dimensions in mm

P-TO220-7-2
 (Plastic Transistor Single Outline)

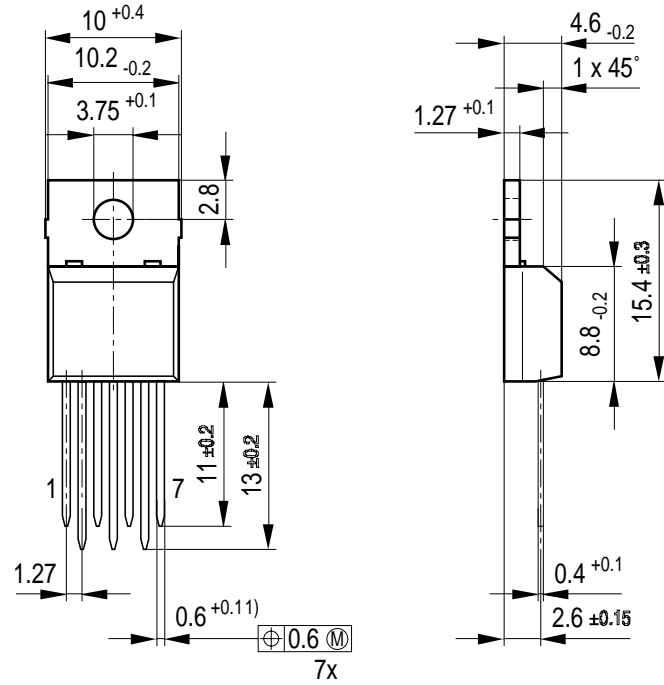

- 1) $0.75^{-0.15}$ at dam bar (max 1.8 from body)
- 1) $0.75^{-0.15}$ im Dichtstegbereich (max 1.8 vom Körper)

GPT05257

Sorts of Packing

Package outlines for tubes, trays etc. are contained in our Data Book "Package Information".

Dimensions in mm