



ON Semiconductor®

<http://onsemi.com>

LV5684PVD

Bi-CMOS LSI

Multi-Power Supply IC for Car Audio Systems

Overview

The LV5684PVD is a power supply IC suitable for USB/CD receiver system for car audio system.

This IC integrates 5 systems of regulator output, 2 systems of high side power switch, overcurrent protector, overvoltage protector and overheat protector

Supply for V_{DD} and SW33V outputs is low voltage specification, which enables drastic reduction of power dissipation compared to the existing model. (the package is HZIP15).

Features

- Low consumption current: 50μA (typ, only V_{DD} output is in operation)
- 5 systems of regulator output
 - V_{DD} for microcontroller: output voltage: 3.3V, maximum output current: 350mA reverse current protection implemented.
 - For system: output voltage: 3.3V, maximum output current: 450mA
 - For audio: output voltage: 5 to 9V (set by external resistors), maximum output current: 250mA
 - For illumination: output voltage: 5 to 12V (set by external resistors), maximum output current: 300mA
 - For CD: output voltage: 5V/8V, maximum output current: 1300mA
- 2 lines of high side switch with interlock V_{CC}
 - EXT: Maximum output current: 350mA, voltage difference between input and output: 0.5V
 - ANT: Maximum output current: 300mA, voltage difference between input and output: 0.5V
- Supply input
 - V_{6IN}: 6V for V_{DD}, system (SW33V)
 - V_{CC1}: For internal reference voltage, control circuits
 - In case of voltage drop of V_{6IN}, V_{CC1} supplies to V_{DD} output.
 - V_{CC2}: For AUDIO, illumination, CD, EXT/ANT
- Overcurrent protector
- Overvoltage protector(OVP): V_{CC1}, V_{CC2} Typ 23V (All outputs except V_{DD} are turned off)
- Overvoltage shutdown(OVS): V_{6IN} Typ 23V (All outputs except V_{DD} are turned off)
- Overheat protector: Typ 175°C
- PchLDMOS is used in power output block

(Warning) The protector functions only improve the IC's tolerance and they do not guarantee the safety of the IC if used under the conditions out of safety range or ratings. Use of the IC such as use under overcurrent protection range, thermal shutdown state or V_{6IN} OVS condition may degrade the IC's reliability and eventually damage the IC.

LV5684PVD

Specifications

Absolute Maximum Ratings at $T_a = 25^\circ\text{C}$

Parameter	Conditions	Conditions	Ratings	Unit	
Supply voltage	V_{CC} max	V_{CC1} , V_{CC2}	36	V	
	V_{6IN} max	V_{6IN} (*)	7	V	
Input voltage	V_{IN} max	CTRL1, CTRL2	7	V	
Allowable power dissipation	P_d max	Independent IC	$T_a \leq 25^\circ\text{C}$	1.3	W
		Al heat sink *		5.3	W
		With an infinity heat sink		26	W
Peak supply voltage	V_{CC} peak	See below for the waveform applied.	50	V	
Operating ambient temperature	T_{opr}		-40 to +85	$^\circ\text{C}$	
Storage temperature	T_{stg}		-55 to +150	$^\circ\text{C}$	
Junction temperature	T_j max		150	$^\circ\text{C}$	

* : When the Aluminum heat sink (50mm × 50mm × 1.5mm) is used

Stresses exceeding Maximum Ratings may damage the device. Maximum Ratings are stress ratings only. Functional operation above the Recommended Operating Conditions is not implied. Extended exposure to stresses above the Recommended Operating Conditions may affect device reliability.

Waveform of surge test (V_{CC1} , V_{CC2})

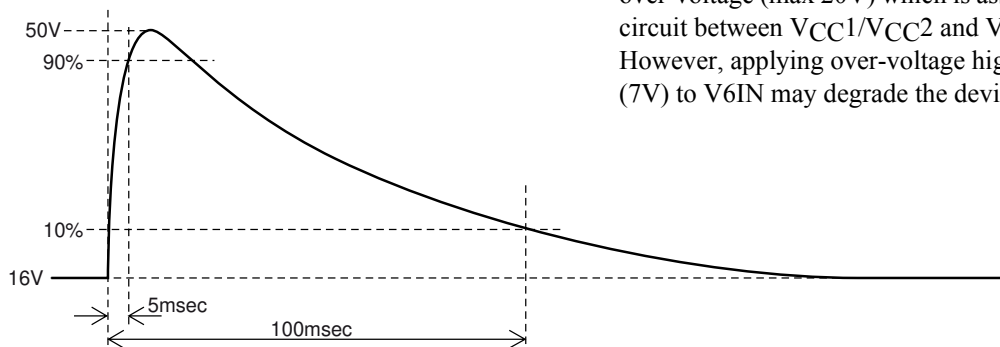

* V_{6IN} is designed to tolerant toward short period of over-voltage (max 20V) which is assumed in condition of short circuit between V_{CC1}/V_{CC2} and V_{6IN} . However, applying over-voltage higher than maximum rating (7V) to V_{6IN} may degrade the device reliability

Recommended Operating range at $T_a = 25^\circ\text{C}$

V_{CC1}

Parameter	Conditions	Ratings	Unit
Operating supply voltage 1	V_{DD} output	7 to 16	V

V_{CC2}

Parameter	Conditions	Ratings	Unit
Operating supply voltage 2	ILM output (10V)	12 to 16	V
	ILM output (8V)	10 to 16	V
Operating supply voltage 3	AUDIO output (9V)	10 to 16	V
Operating supply voltage 4	CD output ($I_O = 1.3\text{A}$)	10.5 to 16	V
	CD output ($I_O \leq 1\text{A}$)	10 to 16	V
Operating supply voltage 5	EXT output, ANT output	10 to 16	V

V_{6IN}

Parameter	Conditions	Ratings	Unit
Operating supply voltage 6	V_{DD} output, SW33V output	5.7 to 6.5	V

LV5684PVD

Electrical Characteristics at $V_{CC1} = V_{CC2} = 14.4V$, $V_{6IN} = 6V$ at $T_a = 25^\circ C$ (*1)

Parameter	Symbol	Conditions	Ratings			Unit
			min	typ	max	
Quiescent current	I_{CC}	V_{DD} w/out load, CTRL1/2 = "L/L"		50	100	μA
CTRL1 input (ANT/EXT/ILM)						
Low input voltage	V_{IL1}		0		0.5	V
M1 input voltage	V_{IM11}		0.8	1.1	1.4	V
M2 input voltage	V_{IM21}		1.9	2.2	2.5	V
High input voltage	V_{IH1}		2.9	3.3	5.5	V
Input impedance	R_{IH1}	input voltage $\leq 3.3V$	280	400	480	$k\Omega$
CTRL2 input (CD/AUDIO/SW33V)						
Low input voltage	V_{IL2}		0		0.5	V
M1 input voltage	V_{IM12}		0.8	1.1	1.4	V
M2 input voltage	V_{IM22}		1.9	2.2	2.5	V
High input voltage	V_{IH2}		2.9	3.3	5.5	V
Input impedance	R_{IH2}	input voltage $\leq 3.3V$	280	400	480	$k\Omega$
V_{DD} output (3.3V) (reverse current prevention diode implemented)						
Output voltage	V_{O1}	$I_{O1} = 200mA$	3.13	3.3	3.47	V
Output current	I_{O1}	$V_{O1} \geq 3.1V$	350			mA
Line regulation	ΔV_{OLN1}	$5.7V < V_{6IN} < 6.5V$, $I_{O1} = 200mA$ or $V_{6IN} = 0V$, $7.5V < V_{CC1} < 16V$, $I_{O1} = 200mA$		30	90	mV
Load regulation	ΔV_{OLD1}	$1mA < I_{O1} < 200mA$		70	150	mV
Dropout voltage	V_{DROP1}	$I_{O1} = 200mA$, $V_{6IN} = 0V$ (applicable to V_{CC1})		2.8	3.5	V
Ripple rejection (*2)	R_{REJ1}	$f = 120Hz$, V_{6IN} or $V_{CC1} = 0.5V_{pp}$ $I_{O1} = 200mA$	40	50		dB
Reverse current	I_{rev}	$V_{O1} = 3.3V$, $V_{CC1} = V_{6IN} = 0V$		1	50	μA
SW33V output (3.3V) ; CTRL2 = "M1 or M2 or H"						
Output voltage	V_{O2}	$I_{O2} = 200mA$	3.13	3.3	3.47	V
Output current	I_{O2}	$V_{O2} \geq 3.1V$	450			mA
Line regulation	ΔV_{OLN2}	$5.7V < V_{6IN} < 6.5V$, $I_{O2} = 200mA$		30	90	mV
Load regulation	ΔV_{OLD2}	$1mA < I_{O2} < 200mA$		70	150	mV
Dropout voltage	V_{DROP2}	$I_{O2} = 200mA$		0.25	0.5	V
Ripple rejection (*2)	R_{REJ2}	$f = 120Hz$, V_{6IN} or $V_{CC1} = 0.5V_{pp}$ $I_{O2} = 200mA$	40	50		dB
AUDIO (5-9V)output ; CTRL2 = "M1 or M2 or H"						
AUDIO_F voltage	V_{I3}		1.212	1.25	1.288	V
AUDIO_F input current	I_{IN3}		-1		1	μA
AUDIO output voltage 1	V_{O3}	$I_{O3} = 150mA$, $R_3 = 30k\Omega$, $R_4 = 5.6k\Omega$ (*3)	7.65	8.0	8.35	V
AUDIO output voltage 2	V_{O3}'	$I_{O3} = 150mA$, $R_3 = 27k\Omega$, $R_4 = 4.7k\Omega$ (*3)	8.13	8.5	8.87	V
AUDIO output voltage 3	V_{O3}''	$I_{O3} = 150mA$, $R_3 = 24k\Omega$, $R_4 = 3.9k\Omega$ (*3)	8.6	9.0	9.4	V
AUDIO output voltage 4	V_{O3}'''	$I_{O3} = 150mA$, $R_3 = 30k\Omega$, $R_4 = 10k\Omega$ (*3)	4.75	5.0	5.25	V
AUDIO output current	I_{O3}		250			mA
Line regulation	ΔV_{OLN3}	$10V < V_{CC2} < 16V$, $I_{O3} = 150mA$		30	90	mV
Load regulation	ΔV_{OLD3}	$1mA < I_{O3} < 150mA$		70	150	mV
Dropout voltage 1	V_{DROP3}	$I_{O3} = 150mA$		0.3	0.45	V
Ripple rejection (*2)	R_{REJ3}	$f = 120Hz$, $I_{O3} = 150mA$	40	50		dB
ILM (5-12V) output ; CTRL1 = "M1 or M2 or H"						
ILM_F voltage	V_{I4}		1.212	1.25	1.288	V
ILM_F input current	I_{IN4}		-1		1	μA
ILM output voltage 1	V_{O4}	$I_{O4} = 200mA$, $R_1 = 43k\Omega$, $R_2 = 5.1k\Omega$ (*3)	11.21	11.8	12.39	V
ILM output voltage 2	V_{O4}'	$I_{O4} = 200mA$, $R_1 = 56k\Omega$, $R_2 = 7.5k\Omega$ (*3)	9.97	10.5	11.03	V

*1 : All the specification is defined based on the tests performed under the conditions where T_j and T_a ($= 25^\circ C$) are almost equal. These tests were performed with pulse load to minimize the increase of junction temperature (T_j).

*2 : guaranteed by design

*3 : Using resistors of tolerance within 1%.

Continued on next page.

LV5684PVD

Continued from preceding page.

Parameter	Symbol	Conditions	Ratings			Unit
			min	typ	max	
ILM output voltage 3	$V_{O4''}$	$I_{O4} = 200\text{mA}$, $R1 = 30\text{k}\Omega$, $R2 = 5.6\text{k}\Omega$ (*3)	7.6	8.0	8.4	V
ILM output voltage 4	$V_{O4'''}$	$I_{O4} = 200\text{mA}$, $R1 = 30\text{k}\Omega$, $R2 = 10\text{k}\Omega$ (*3)	4.75	5.0	5.25	V
ILM output current	I_{O4}		300			mA
Line regulation	ΔV_{OLN4}	$10\text{V} < V_{CC2} < 16\text{V}$, $I_{O4} = 200\text{mA}$ $R1 = 30\text{k}\Omega$, $R2 = 5.6\text{k}\Omega$		30	90	mV
Load regulation	ΔV_{OLD4}	$1\text{mA} < I_{O4} < 200\text{mA}$		70	150	mV
Dropout voltage 1	V_{DROP4}	$I_{O4} = 200\text{mA}$		0.7	1.05	V
Dropout voltage 2	$V_{DROP4'}$	$I_{O4} = 100\text{mA}$		0.35	0.53	V
Ripple rejection (*2)	R_{REJ4}	$f = 120\text{Hz}$, $I_{O4} = 200\text{mA}$	40	50		dB
CD (5V/8V output) ; CTRL2 = "H" : 8V, CTRL2 = "M2" : 5V						
Output voltage	V_{O51}	$I_{O5} = 1000\text{mA}$	4.75	5.0	5.25	V
	V_{O52}	$I_{O5} = 1000\text{mA}$	7.6	8.0	8.4	V
Output current	I_{O5}	$V_{O51} \geq 4.7\text{V}$, $V_{O52} \geq 7.6\text{V}$	1300			mA
Line regulation	ΔV_{OLN5}	$10.5\text{V} < V_{CC2} < 16\text{V}$, $I_{O5} = 1000\text{mA}$		50	100	mV
Load regulation	ΔV_{OLD5}	$10\text{mA} < I_{O5} < 1000\text{mA}$		100	200	mV
Dropout voltage 1	V_{DROP5}	$I_{O5} = 1000\text{mA}$		1.0	1.5	V
Dropout voltage 2	$V_{DROP5'}$	$I_{O5} = 500\text{mA}$		0.5	0.75	V
Ripple rejection (*2)	R_{REJ5}	$f = 120\text{Hz}$, $I_{O5} = 1000\text{mA}$	40	50		dB
EXT_HS-SW ; CTRL1 = "M2 or H"						
Output voltage	V_{O6}	$I_{O6} = 350\text{mA}$	$V_{CC2-1.0}$	$V_{CC2-0.5}$		V
Output current	I_{O6}	$V_{O6} \geq V_{CC2-1.0}$	350			mA
ANT_HS-SW ; CTRL1 = "H"						
Output voltage	V_{O7}	$I_{O7} = 300\text{mA}$	$V_{CC2-1.0}$	$V_{CC2-0.5}$		V
Output current	I_{O7}	$V_{O7} \geq V_{CC2-1.0}$	300			mA

*2 : guaranteed by design

*3 : Using resistors of tolerance within 1%.

CTRL logic truth table

CTRL1	ANT	EXT	ILM
H	ON	ON	ON
M2	OFF	ON	ON
M1	OFF	OFF	ON
L	OFF	OFF	OFF

CTRL2	CD	AUDIO	SW33V
H	ON (8V)	ON	ON
M2	ON (5V)	ON	ON
M1	OFF	ON	ON
L	OFF	OFF	OFF

CTRL1/2 voltage range and threshold

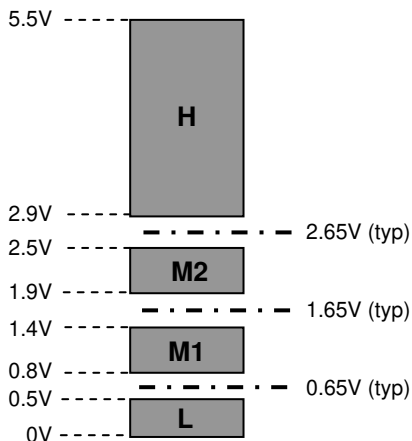

LV5684PVD

Package Dimensions

unit : mm (typ)
3336

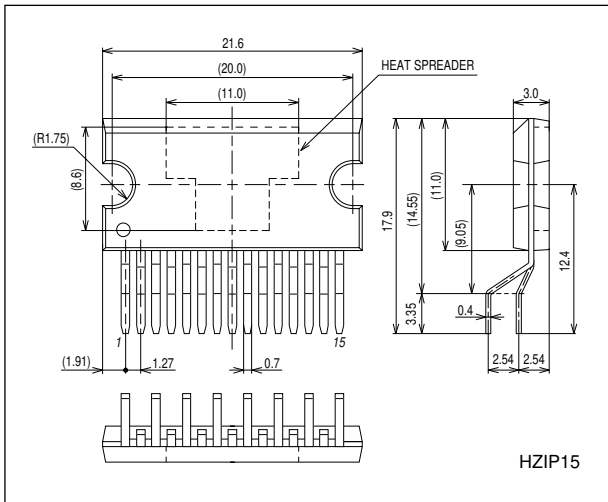

• Allowable power dissipation derating curve

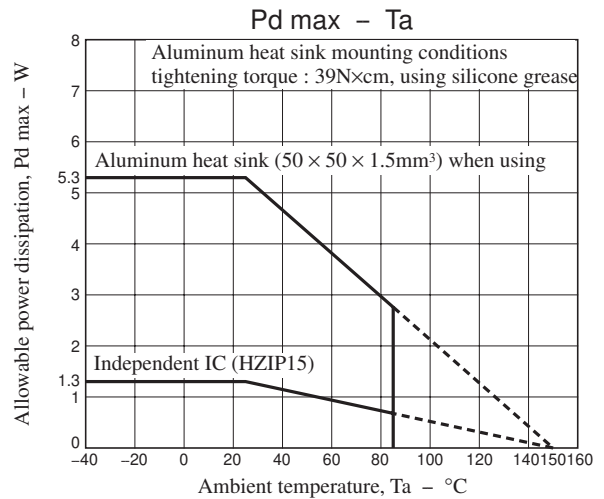

Application Circuit Example

LV5684PVD

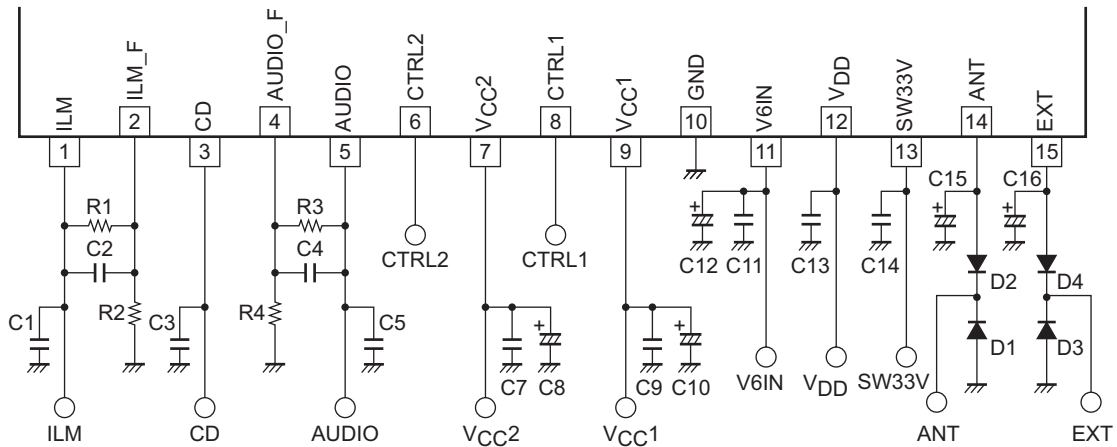

Peripheral parts

Part name	Description	Recommended value	Note
C1, C3, C5, C13, C14	output stabilization capacitor	greater than 10 μ F (*1)	
C2, C4	output stabilization capacitor	0pF	Ceramic capacitor
C8, C10, C12	Capacitor for bypass power supply	C8: greater than 100 μ F C10, C12: greater than 47 μ F	Make sure to implement close to V _{CC} and GND.
C7, C9, C11	Capacitor for oscillation protector	greater than 0.22 μ F	
C15, C16	Capacitor for EXT/ANT output stabilization	greater than 2.2 μ F	
R1, R2	ILM voltage setting	R1/R2 43k Ω /5.1k Ω : V _O = 12V 56k Ω /7.5k Ω : V _O = 10.5V 30k Ω /5.6k Ω : V _O = 8V 30k Ω /10k Ω : V _O = 5V	Use resistors of tolerance within 1%
R3, R4	AUDIO voltage setting	R3/R4 30k Ω /10k Ω : V _O = 5V 30k Ω /5.6k Ω : V _O = 8.0V 27k Ω /4.7k Ω : V _O = 8.5V 24k Ω /3.9k Ω : V _O = 9V	Use resistors of tolerance within 1%
D1, D2, D3, D4	Internal device protector diode	SB1003M3	

(*1) Make sure that output capacitors are greater than 10 μ F and meets the condition of ESR = 0.001 to 10 Ω , in which voltage/ temperature dependence and unit differences are taken into consideration. Moreover, in case of electrolytic capacitor, high-frequency characteristics should be sufficiently good.

LV5684PVD

Block Diagram

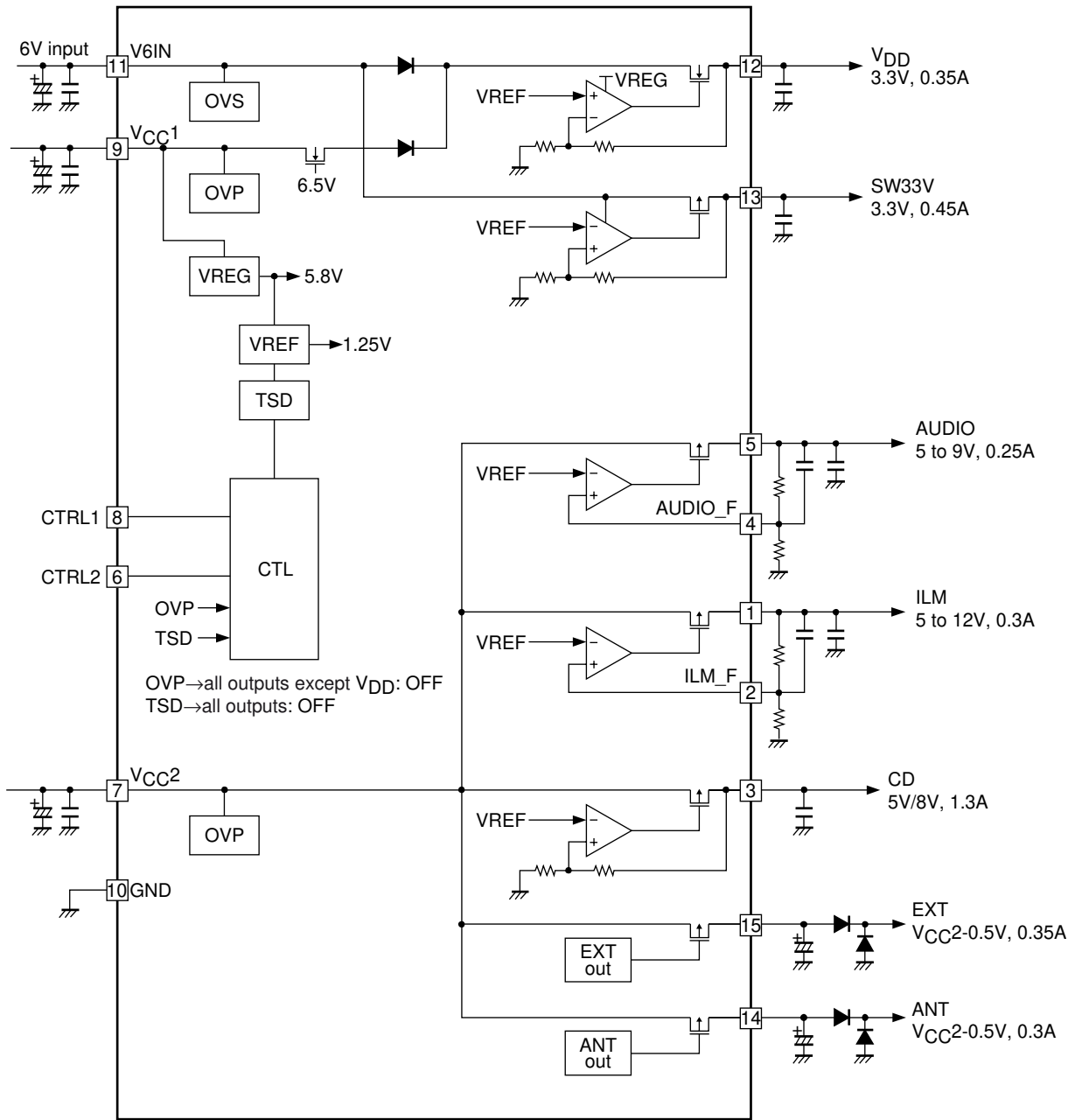

Pin Function

Pin No.	Pin name	Description	Equivalent Circuit
1	ILM	ILM output When CTRL1 = M1, M2, H, ILM is ON	
2	ILM_F	ILM voltage adjust	

Continued on next page.

LV5684PVD

Continued from preceding page.

Pin No.	Pin name	Description	Equivalent Circuit
3	CD	CD output When CTRL2 = M2, H, CD is ON 5V or 8V/1.3A	
4	AUDIO_F	AUDIO voltage adjust	
5	AUDIO	AUDIO output When CTRL2 = M1, M2, H, AUDIO is ON	
6	CTRL2	CTRL2 input 4-value input	
7	V _{CC2}	Power supply	
8	CTRL1	CTRL1 input 4-value input	
9	V _{CC1}	Power supply	
10	GND	GND	
11	V6IN	Power supply	

Continued on next page.

LV5684PVD

Continued from preceding page.

Pin No.	Pin name	Description	Equivalent Circuit
12	V _{DD}	V _{DD} output 3.3V/0.35A	
13	SW33V	SW33V output When CTRL2 = M1, M2, H, SW33V is ON 3.3V/0.45A	
14	ANT	ANT output When CTRL1 = H, ANT is ON V _{CC} -0.5V/300mA	
15	EXT	EXT output When CTRL1 = M2, H, EXT is ON V _{CC} -0.5V/350mA	

LV5684PVD

Timing Chart

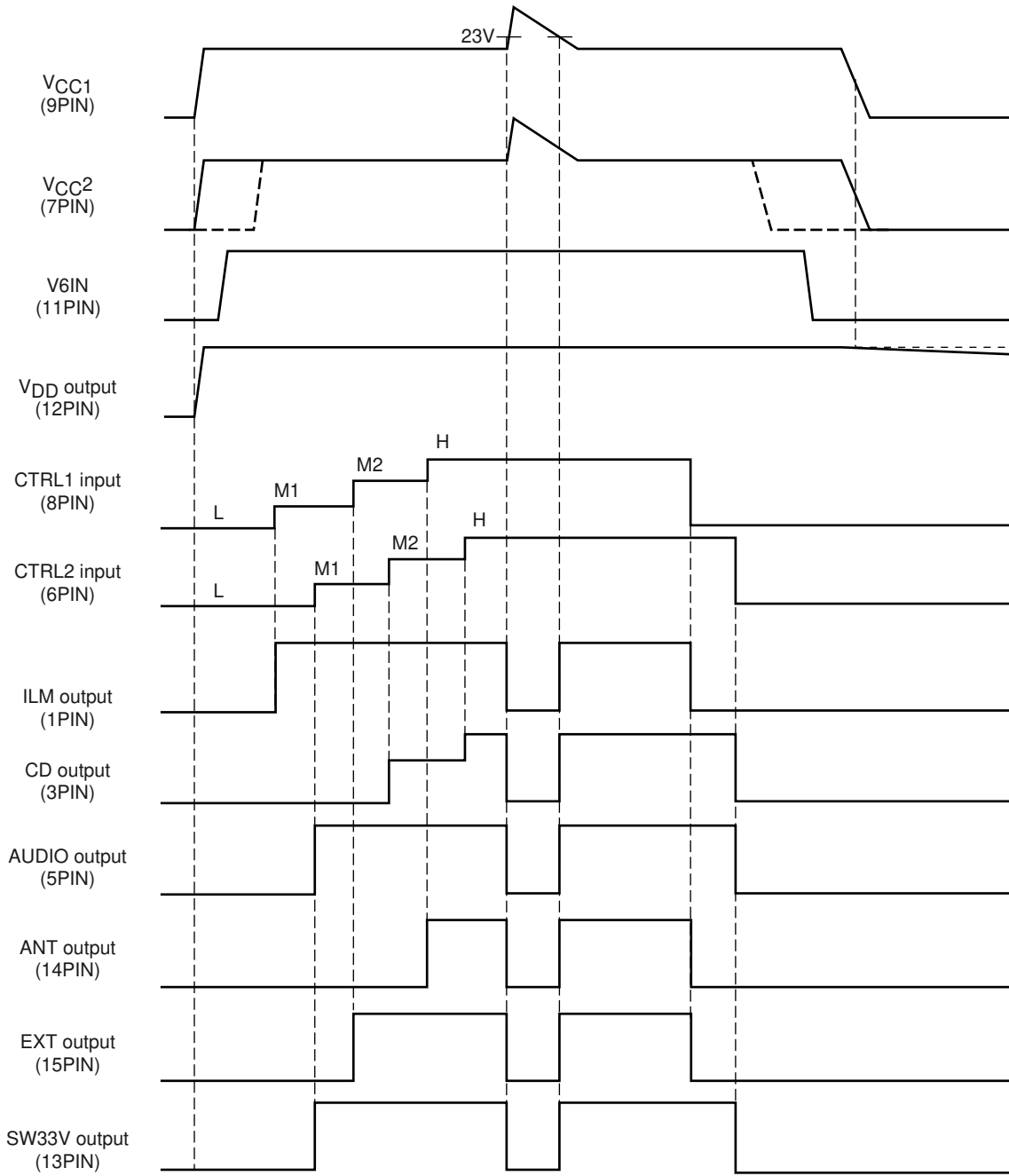

Caution: The above values are obtained when typ.

LV5684PVD

- How to set AUDIO output voltage

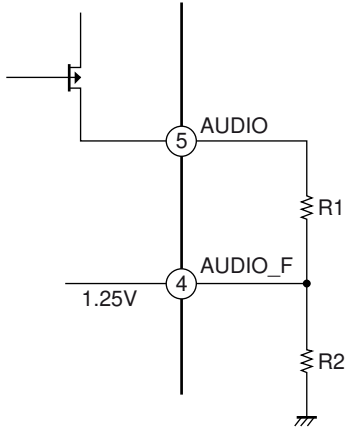

{
 AUDIO_F is determined by internal band-gap reference voltage (typ = 1.25V).
 }

AUDIO output voltage expression

$$AUDIO = \left(\frac{R_1}{R_2} + 1\right) \times 1.25[V]$$

$$\frac{R_1}{R_2} = \frac{AUDIO}{1.25} - 1$$

Set the ratio of R1 and R2 to satisfy above expression.

(ex) AUDIO = 9V setting

$$\frac{R_1}{R_2} = \frac{9}{1.25} - 1 = 6.2$$

$$\frac{R_1}{R_2} = \frac{24k\Omega}{3.9k\Omega} \cong 6.15$$

$$AUDIO = (6.15 + 1) \times 1.25V \cong \boxed{8.94V}$$

- ILM output voltage is similarly calculated as AUDIO output.

(ex) ILM = 10.5V setting

$$\frac{R_1}{R_2} = \frac{10.5}{1.25} - 1 = 7.4$$

$$\frac{R_1}{R_2} = \frac{56k\Omega}{7.5k\Omega} \cong 7.46$$

$$ILM = (7.46 + 1) \times 1.25V \cong \boxed{10.575V}$$

Note : The above values are typical values. These values have variation among the range of their tolerances.

HZIP15 Heat sink attachment

Heat sinks are used to lower the semiconductor device junction temperature by leading the heat generated by the device to the outer environment and dissipating that heat.

- a. Unless otherwise specified, for power ICs with tabs and power ICs with attached heat sinks, solder must not be applied to the heat sink or tabs.

b. Heat sink attachment

- Use flat-head screws to attach heat sinks.
- Use also washer to protect the package.
- Use tightening torques in the ranges 39-59Ncm (4-6kgcm) .
- If tapping screws are used, do not use screws with a diameter larger than the holes in the semiconductor device itself.
- Do not make gap, dust, or other contaminants to get between the semiconductor device and the tab or heat sink.
- Take care a position of via hole .
- Do not allow dirt, dust, or other contaminants to get between the semiconductor device and the tab or heat sink.
- Verify that there are no press burrs or screw-hole burrs on the heat sink.
- Warping in heat sinks and printed circuit boards must be no more than 0.05 mm between screw holes, for either concave or convex warping.
- Twisting must be limited to under 0.05 mm.
- Heat sink and semiconductor device are mounted in parallel.
Take care of electric or compressed air drivers
- The speed of these torque wrenches should never exceed 700 rpm, and should typically be about 400 rpm.

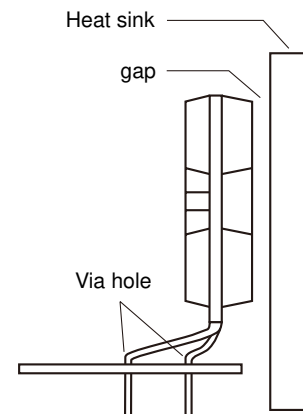
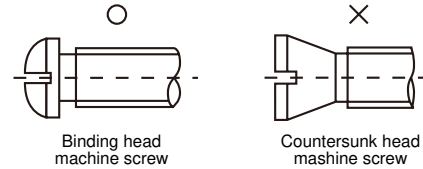

c. Silicone grease

- Spread the silicone grease evenly when mounting heat sinks.
- Our company recommends YG-6260 (Momentive Performance Materials Japan LLC)

d. Mount

- First mount the heat sink on the semiconductor device, and then mount that assembly on the printed circuit board.
- When attaching a heat sink after mounting a semiconductor device into the printed circuit board, when tightening up a heat sink with the screw, the mechanical stress which is impossible to the semiconductor device and the pin doesn't hang.

e. When mounting the semiconductor device to the heat sink using jigs, etc.,

- Take care not to allow the device to ride onto the jig or positioning dowel.
- Design the jig so that no unreasonable mechanical stress is applied to the semiconductor device.

f. Heat sink screw holes

- Be sure that chamfering and shear drop of heat sinks must not be larger than the diameter of screw head used.
- When using nuts, do not make the heat sink hole diameters larger than the diameter of the head of the screws used. A hole diameter about 15% larger than the diameter of the screw is desirable.
- When tap screws are used, be sure that the diameter of the holes in the heat sink are not too small. A diameter about 15% smaller than the diameter of the screw is desirable.

- g. There is a method to mount the semiconductor device to the heat sink by using a spring band. But this method is not recommended because of possible displacement due to fluctuation of the spring force with time or vibration.

ON Semiconductor and the ON logo are registered trademarks of Semiconductor Components Industries, LLC (SCILLC). SCILLC owns the rights to a number of patents, trademarks, copyrights, trade secrets, and other intellectual property. A listing of SCILLC's product/patent coverage may be accessed at www.onsemi.com/site/pdf/Patent-Marking.pdf. SCILLC reserves the right to make changes without further notice to any products herein. SCILLC makes no warranty, representation or guarantee regarding the suitability of its products for any particular purpose, nor does SCILLC assume any liability arising out of the application or use of any product or circuit, and specifically disclaims any and all liability, including without limitation special, consequential or incidental damages. "Typical" parameters which may be provided in SCILLC data sheets and/or specifications can and do vary in different applications and actual performance may vary over time. All operating parameters, including "Typicals" must be validated for each customer application by customer's technical experts. SCILLC does not convey any license under its patent rights nor the rights of others. SCILLC products are not designed, intended, or authorized for use as components in systems intended for surgical implant into the body, or other applications intended to support or sustain life, or for any other application in which the failure of the SCILLC product could create a situation where personal injury or death may occur. Should Buyer purchase or use SCILLC products for any such unintended or unauthorized application, Buyer shall indemnify and hold SCILLC and its officers, employees, subsidiaries, affiliates, and distributors harmless against all claims, costs, damages, and expenses, and reasonable attorney fees arising out of, directly or indirectly, any claim of personal injury or death associated with such unintended or unauthorized use, even if such claim alleges that SCILLC was negligent regarding the design or manufacture of the part. SCILLC is an Equal Opportunity/Affirmative Action Employer. This literature is subject to all applicable copyright laws and is not for resale in any manner.